

KVM Matrix Switch Routers Product Manual

Covering the following models:

**VX40, VX80, VX160, VX320,
VX320VIDEO & VX320AUDIO**

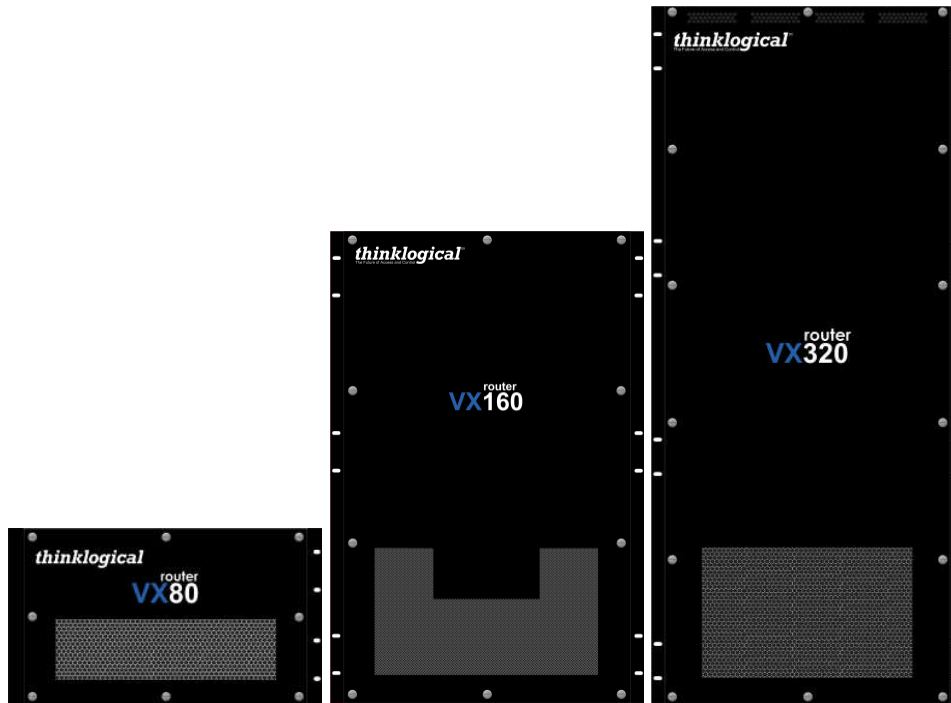

Value Your Content

thinklogical[®]

Trust Our Proven Ingenuity

Thinklogical, LLC[®]
100 Washington Street
Milford, Connecticut 06460 U.S.A.
Telephone: 1-203-647-8700
Fax: 1-203-783-9949
www.thinklogical.com

Value Your Content

thinklogical®

Trust Our Proven Ingenuity

Copyright Notice

Copyright © 2013. All rights reserved. Printed in the U.S.A.

Thinklogical, LLC®
100 Washington Street
Milford, Connecticut 06460 U.S.A.
Telephone: 1-203-647-8700

All trademarks and service marks are property of their respective owners.

Subject: VX40, VX80, VX160, VX320, VX320Video, VX320Audio Router Product Manual
Revision: N, September 2013

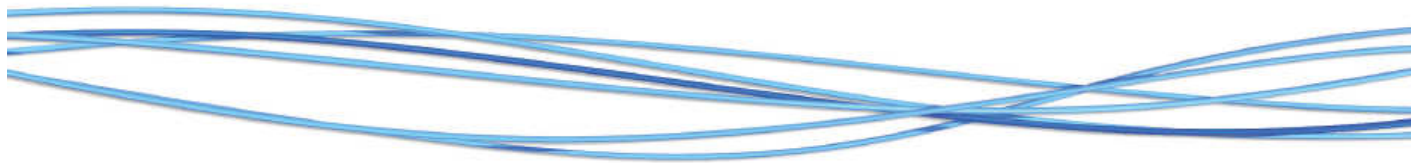

VX40



VX80



VX160



VX320



VX320



X4

Video/Audio Configurator



thinklogical®



Table of Contents

PREFACE	4
About this Product Manual.....	4
Conventions Used in this Manual	4
Laser Information.....	4
INTRODUCTION	5
The Logical Solution	5
Theory of Operation.....	6
MRTS Technology	6
System Features	7
Technical Specifications	8
VX Router Rear Panel Views.....	9
PART 1: HARDWARE	14
Contents.....	14
VX Router Modules	16
Power Supplies	16
Fan Tray and Alarms	16
The Controller Cards	18
External Control CPU Minimum Requiements.....	19
VX Router DIP Switch Settings	19
The Input/Output Cards	20
Pluggable SFP+ Optical Modules.....	26
Fiber Optic Cable.....	27
Fiber Optic Cable Requirements	27
Handling Fiber Optic Cable	27
Installing Fiber into Input/Output Cards	28
Removing Fiber from Input/Output Cards.....	28
Connecting to Thinklogical Velocity Extenders	28
Connecting to the Receiver	28
Connecting to the Transmitter	31
Installation	34
Set-Up	34
Order of Installation Events	35
How to Replace Modules.....	35
How to Install or Replace Input/Output Cards	35
How to Install or Replace a Controller Card	36
How to Replace a Fan Tray.....	36
How to Replace a Power Supply	37
PART 2: REGULATORY & SAFETY REQUIREMENTS	37
Regulatory Compliance.....	37
North America.....	37
Australia & New Zealand.....	38
European Union	38
Standards with Which Our Products Comply.....	38
Supplementary Information.....	38
Product Serial Number	39
Connection to the Product	39
PART 3: THINKLOGICAL SUPPORT	40
Customer Support	40
Website.....	40
Email.....	40
Telephone.....	40
Fax.....	41
Product Support.....	41

Warranty 41
Return Authorization 41

APPENDIX A: ORDERING INFORMATION..... 42
APPENDIX B: QUICK START GUIDES 46
APPENDIX C: SD FLASH CARD REPLACEMENT..... 52
APPENDIX D: SECURE APPLICATIONS..... 57
APPENDIX E: TOUCH PANEL CONFIGURATION..... 68
APPENDIX F: MIB FILE 72

Please note that there is a separate *X4 Configurator (Control Management System with On Screen Display) Manual* available on our website.



X4 Configurator



Thinklogical Innovation Leads the Way.
Performance • Security • Continuous Operation • Ease of Integration

www.thinklogical.com



Preface

About this Product Manual

This product manual is divided into three sections: **Hardware**, **Safety Requirements** and **Product Support**. These are sub-divided to help you find the topics and procedures you are looking for. This manual also contains Appendices.

Part 1 – Hardware: This section of the manual contains all the information and instructions on how to assemble your equipment.

Part 2 – Safety Requirements: Thinklogical strongly recommends that you read this section of the manual prior to starting the hardware assembly.

Part 3 – Product Support: Thinklogical provides the best customer support available. If you have any questions or need to contact the company, please refer to this section of the manual.

Conventions Used in this Manual

As you read this manual you will notice certain conventions that bring your attention to important information. These are **Notes** and **Warnings**. Examples are shown below.



Note: Important Notes appear in blue text preceded by a yellow exclamation point symbol, as shown here.

A note is meant to call the reader's attention to helpful information at a point in the text that is relevant to the subject being discussed.



Warning! All Warnings appear in red text, followed by blue text, and preceded by a red stop sign, as shown here.

A warning is meant to call the reader's attention to critical information at a point in the text that is relevant to the subject being discussed.

Laser Information

VX Routers, like all Thinklogical® products, are designed and identified as **Class 1 LASER products**.

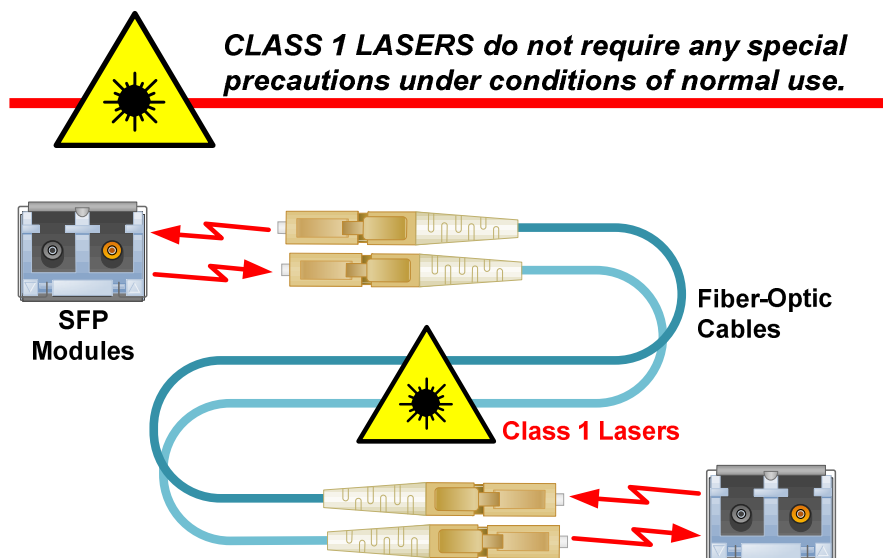

Introduction

The Logical Solution

Thinklogical's VX40, VX80, VX160, VX320 and VX320Video & Audio Routers® are high performance, modular non-blocking matrix switches for complete, end-to-end routing of video and peripheral signals over multi-mode or single-mode fiber optic cable.

These highly reliable and resilient routers provide bidirectional matrix routing and are expandable from 5x5 to 320x320 Duplex ports, allowing for flexible deployment configurations. The VX40, VX80, VX160, VX320, and VX320Video/Audio Routers are available with LC-type fiber connectors.

Thinklogical's VX Routers include:

- Redundant, Current Sharing Power Supply Modules
- Redundant Controller Cards
- Single Fan Tray (includes three fans)

Optional Modules (Spares):

VX40 Router Data Upstream Card, 5 Ports, SFP+
VX40 Router Data Downstream Card, 5 Ports, SFP+
VX40 Router Redundant Controller Card
VX40 Router Power Module
VX40 Router Fan Tray

VX80 Router Data Input/Output Card, 5 Ports, SFP+
VX80 Router Data Downstream Card, 5 Ports, SFP+
VX80 Router Redundant Controller Card
VX80 Router Power Module
VX80 Router Fan Tray

VX160 Router Data Upstream Card, 20 Ports, SFP+
VX160 Router Data Downstream Card, 20 Ports, SFP+
VX160 Router Redundant Controller Card
VX160 Router Power Module
VX160 Router Fan Tray

(For VX320 and VX320 Video/Audio)

VX320 Router Data Input/Output Card, 16 Ports, SFP+
VX320 Router Redundant Controller Card
VX320 Router Controller Card with OSD
VX320 Router Power Module
VX320 Router Fan Tray

See **Appendix A** on page 42 for ordering information on the complete line of the Thinklogical VX Routers.

Also see our **X4 Configurator** Control Management System Manual (available on our website) for administrative set-up and control features and OSD (On Screen Display).

Each Thinklogical® router is NATO, Common Criteria EAL/4 and TEMPEST certified.

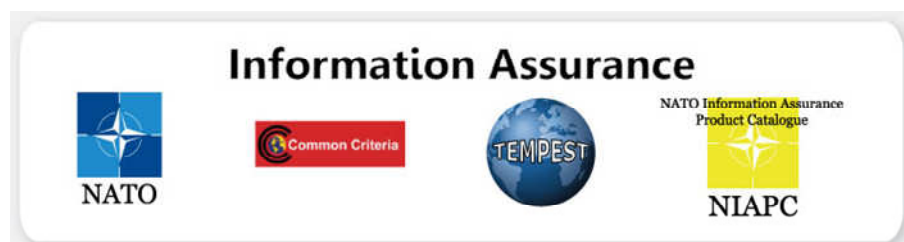

Theory of Operation

MRTS Technology

Thinklogical VX Routers® are used together as a system with our Thinklogical Velocity Extenders® utilizing breakthrough, patent-pending technology for transmission and reception of DVI, keyboard, mouse, and high-speed data peripherals. This technology, known as **Multi Rate Transmission System (MRTS)**, provides end-to-end data transmission with unparalleled performance.

This new, unique optic platform enables multiple data streams to be transmitted long distances over single or multiple fibers with complete reconstruction of the data clock at the destination end point. The result is perfect synchronization with each transmitted stream.

All new products are designated with our “Powered by **MRTS Technology**” logo.



MRTS is a highly reliable technology and delivers powerful benefits to our customers when combined with our new SFP+ optics. The new MRTS Technology has the ability to transport every frame of a 1920 x 1200 @ 60Hz (or higher) video stream with no compression, along with all desktop peripherals (keyboard, mouse, etc., including 480Mbps USB 2.0) with no latency. Moreover, these signals can be transmitted distances from just a few meters over multi-mode fibers or up to 40 kilometers over single-mode fibers.

MRTS allows the incorporation of traditional AV implementations and video routing into the same switch fabric, providing greater value, flexibility, performance and security. Additional unique capabilities include the ability to support 6.25Gbps bandwidth per stream, between 50% and 100% higher than our traditional systems (typically 1.485Gbps to 3.2Gbps). This is significant because a single DVI stream requires a 5.4Gbps data rate to accommodate the 165MHz of video data. Traditional technology’s lower bandwidth capability is generally manifested in either dropped frames or lower resolution associated with compressing schemes. Not so with MRTS Technology.

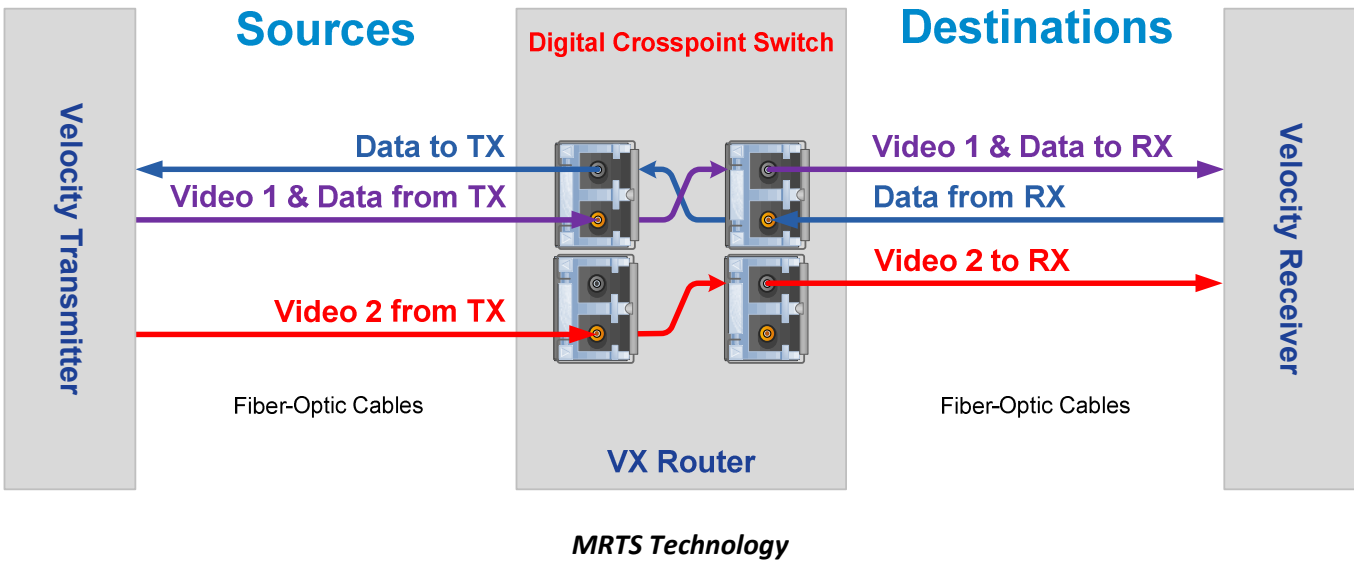

System Features

System Features	VX40/VX80	VX160	VX320	VX320 Video/Audio
Matrix Size	80x80	320 Duplex	640 Duplex	320x320
Matrix Size Non-Blocking	80x80 Duplex Non-Blocking OR 40x40 Duplex Bi-Directional Non-Blocking	160x160 Duplex Bi-Directional Non-Blocking	320x320 Duplex Bi-Directional Non-Blocking	320x320 Duplex Non-Blocking
Scalability	5 Ports	20 Ports (40 min)	16 Ports	16 Ports
Compatible with Velocity KVM and Video Extenders from Thinklogical®	✓	✓	✓	✓
Each Video Connection Supports 6.25 Gbps	✓	✓	✓	✓
Single Mode and Multi Mode	✓	✓	✓	✓
Redundant, Hot-Swappable and Current Sharing Power Supply Modules	✓	✓	✓	✓
Hot Swappable SFP+ Optical Modules	✓	✓	✓	✓
Hot Swappable Fan Tray with Annunciator Port (for alarms)	✓	✓	✓	✓
Hot Swappable Redundant Controller Card (optional)	✓	✓	✓	✓
Controllable via LAN or Serial Connection	✓	✓	✓	✓
SNMP (2C) Control Protocol	✓	✓	✓	✓
X4 Configurator Software Included	✓	✓	✓	✓
Supports Multicasting and Macros	✓	✓	✓	✓

VX Router System Features

Technical Specifications

VX Routers, all models:

Humidity	5-95% RH, non-condensing
Operating Temperature	0-50°C (32-122°F)
Alarm Relay contacts	Maximum DC: 1A at 30VDC Maximum AC: 0.3A at 125VAC Contact resistance maximum: .1Ω
Power Requirements	AC Input: 100-240VAC, 47-63 Hz Universal AC Power Supply

Technical Specifications	VX40/VX80	VX160	VX320	VX320 Video/Audio*
Rack Size Dimensions	EIA 19" (48.26 cm)	EIA 19" (48.26 cm)	EIA 19" (48.26 cm)	EIA 19" (48.26 cm)
Physical Dimensions- Height	6 RU 10.50" (26.70 cm)	16 RU 28.0" (71.12 cm)	24 RU 42.0" (106.60 cm)	13 RU 22.75" (57.8 cm)
Physical Dimensions- Width	17.16" (43.59 cm)	17.19" (43.7 cm)	17.19" (43.7 cm)	17.19" (43.7 cm)
Physical Dimensions- Depth	15.32" (16.57" including card pulls; 42.09 cm)	Depth: 15.0" (15.75" including card pulls; 40 cm)	Depth: 15.32" (15.61" including card pulls; 39.64 cm; w/cable management: 18.36" including card pulls; 46.64 cm)	Depth: 14.2" (15.32" including card pulls; 38.9 cm)
Power Consumption	Approximately 400 Watts Fully Loaded	Approximately 850 Watts Fully Loaded	Approximately 1700 Watts Fully Loaded	Approximately 800 Watts Fully Loaded
Actual Weight	37.1 lbs. (16.83 kg)	103.5 lbs. (46.87 kg)	132.0 lbs. (59.87 kg)	78 lbs. (35.38 kg)
Shipping Weight	100 lbs. (45.36 kg)	152 lbs. (68.95 kg)	160 lbs. (72.57 kg)	100 lbs. (45.36 kg)

*The VX320Video Router uses OSA 40 (6.25G optics) and the VX320Audio Router uses OSA 45 (4G optics)

VX Router Technical Specifications

VX Router Rear Panel Views

NOTE: All modules may be replaced without interruption to other module functions (except for the Primary Controller Card)

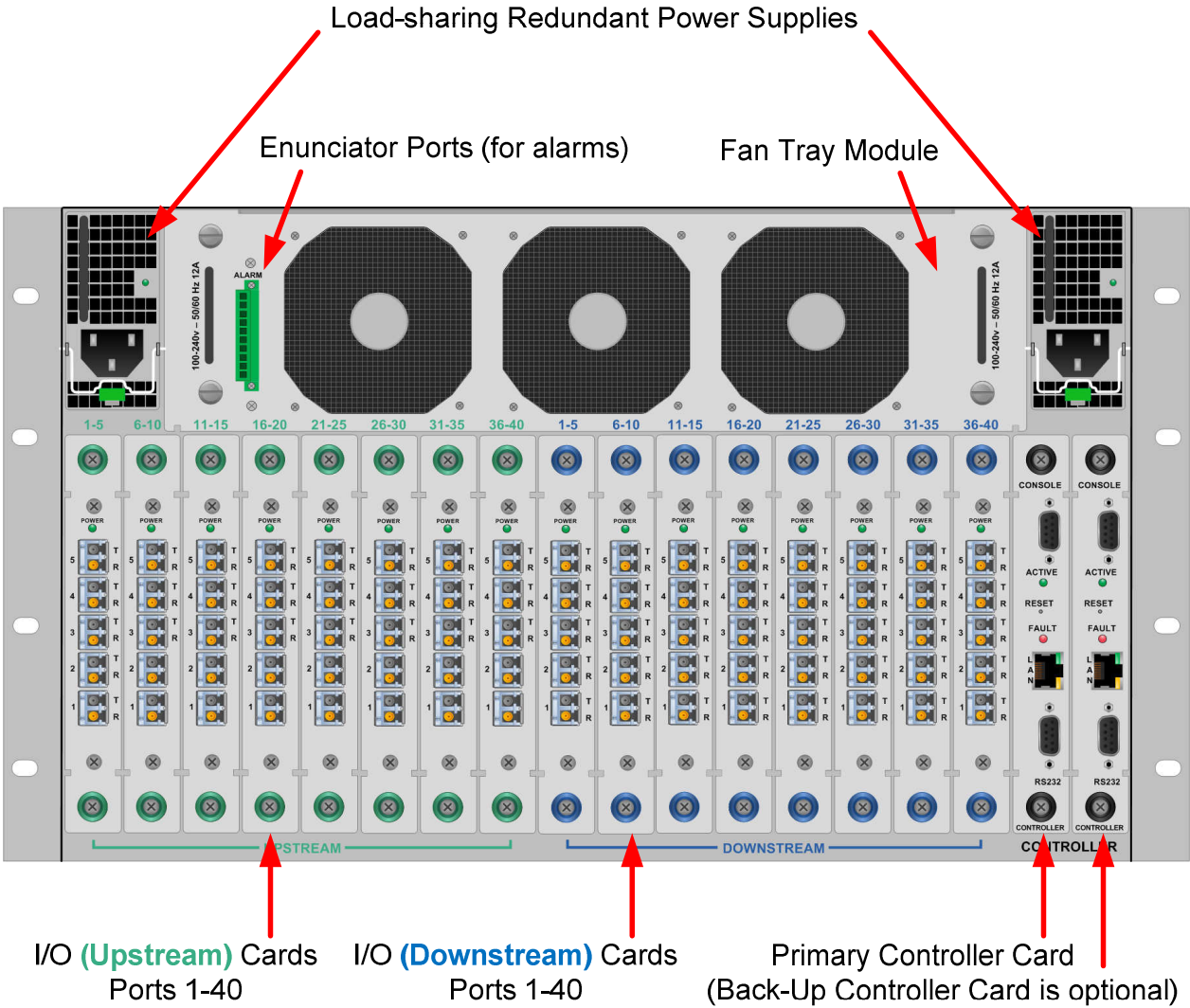

VX40 Router – Rear View

NOTE: All modules may be replaced without interruption to other module functions (except for the Primary Controller Card)

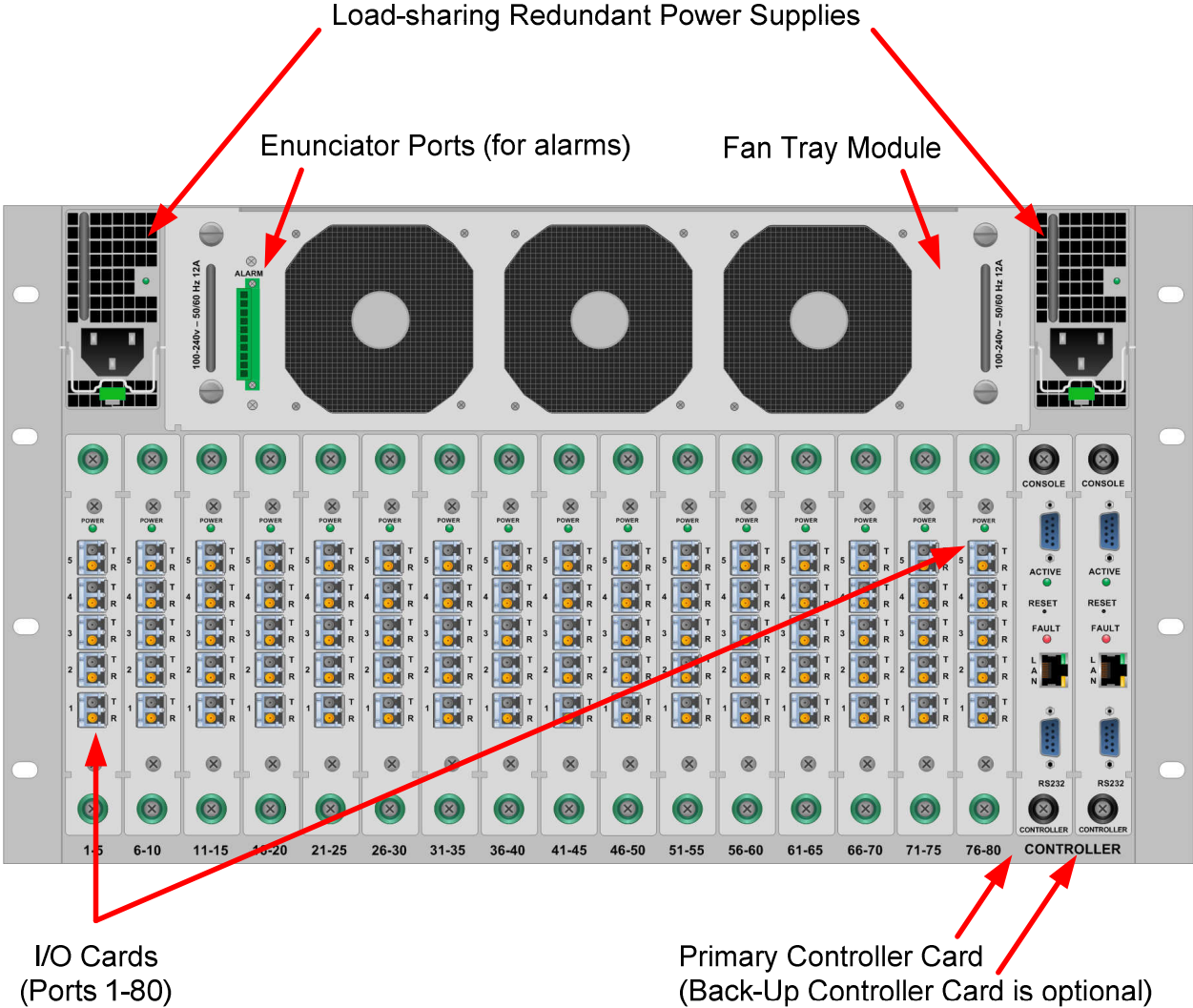

VX80 Router – Rear View

NOTE: All modules may be replaced without interruption to other modules functions (except for the Primary Controller Card)

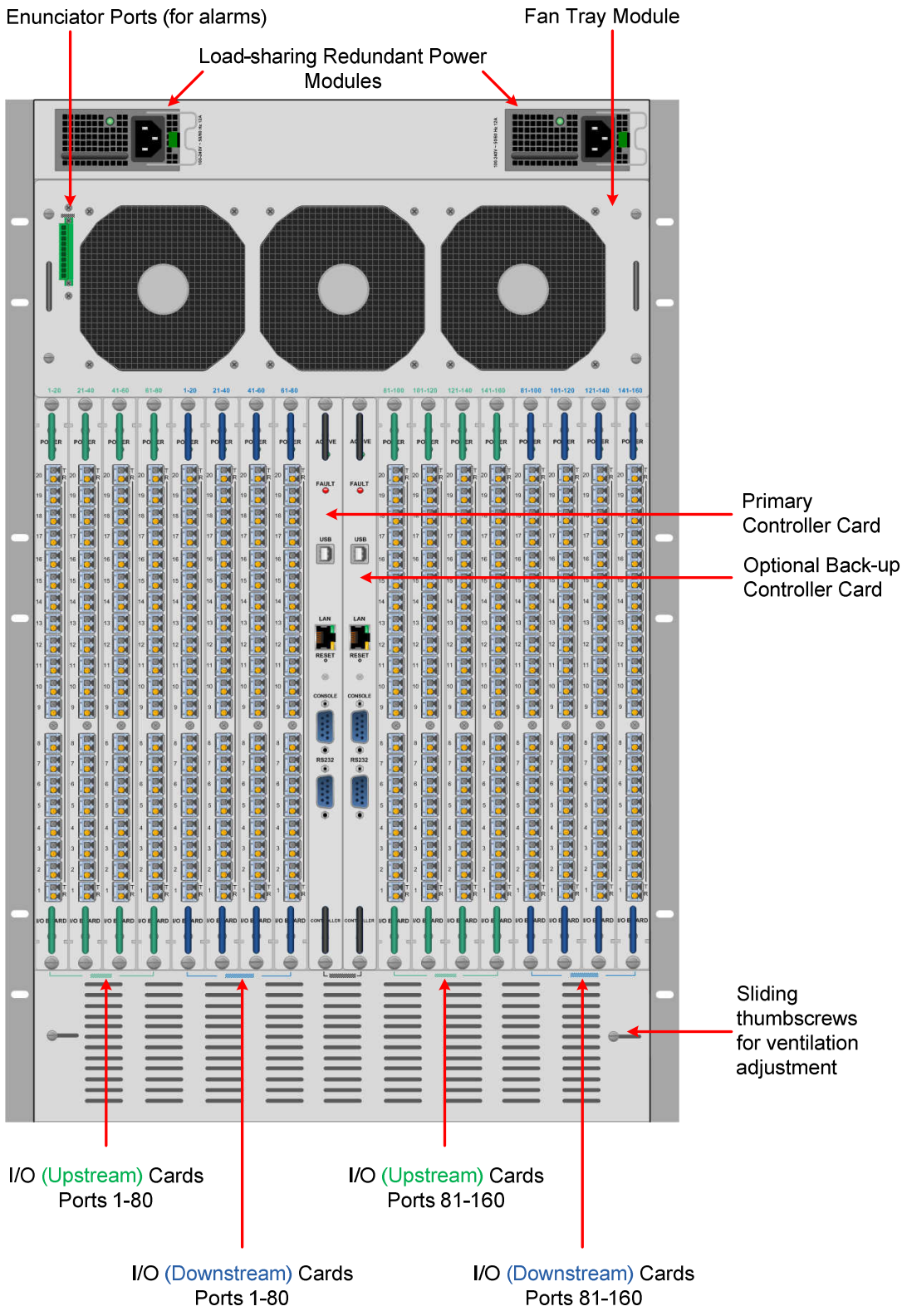

VX160 Router – Rear View

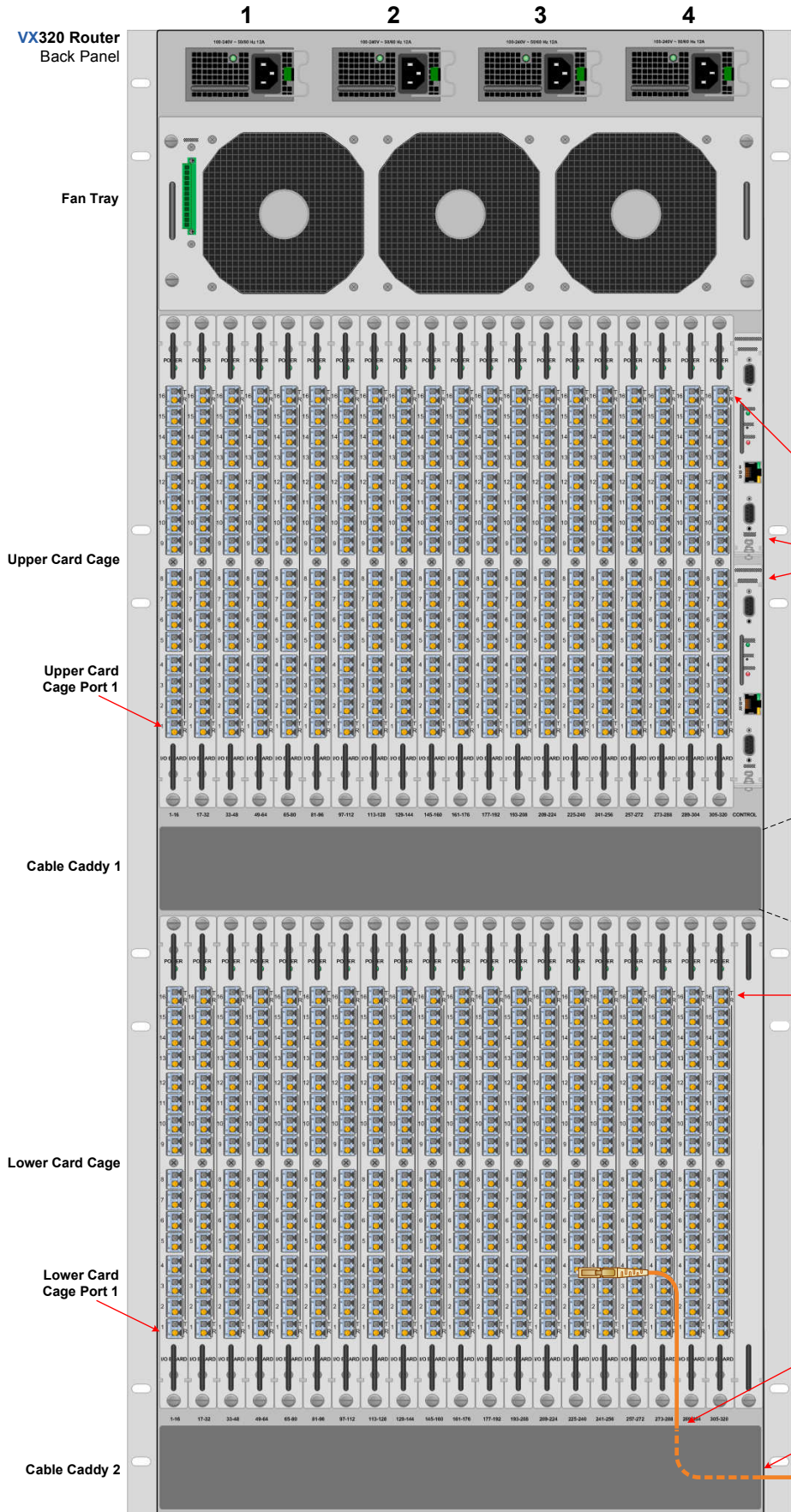

Redundant Power supplies, Left to Right:
 1 Upper Card Cage Primary
 2 Upper Card Cage Back-up
 3 Lower Card Cage Primary
 4 Lower Card Cage Back-up

1700 Watts
VX320 Router KVM Matrix Switch Chassis: 24 Rack Units
 42" High x 17.2" Wide x 14" Deep
 (1066.8mm x 436.88mm x 355.6mm)

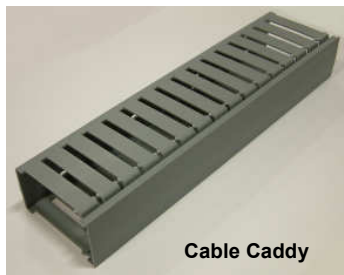

Upper Card Cage Port 320

Primary Controller Card
 Back-up Controller Card

Cable Caddy (2 places):
 4.10" Deep x 2.17" High x 16.0" Wide
 (104.14mm x 55.12mm x 406.4mm)

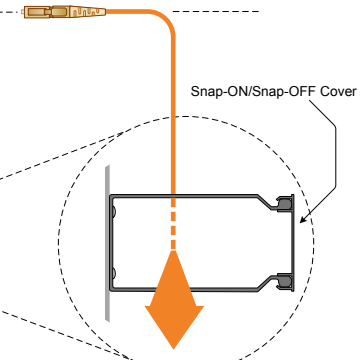

Lower Card Cage Port 320

Fibers enter through top of Caddy...

...emerge from side of Caddy.

VX320 Router – Rear View

NOTE: All modules may be replaced without interruption to other module functions (except for the Primary Controller Card)

VX320VIDEO/AUDIO Router

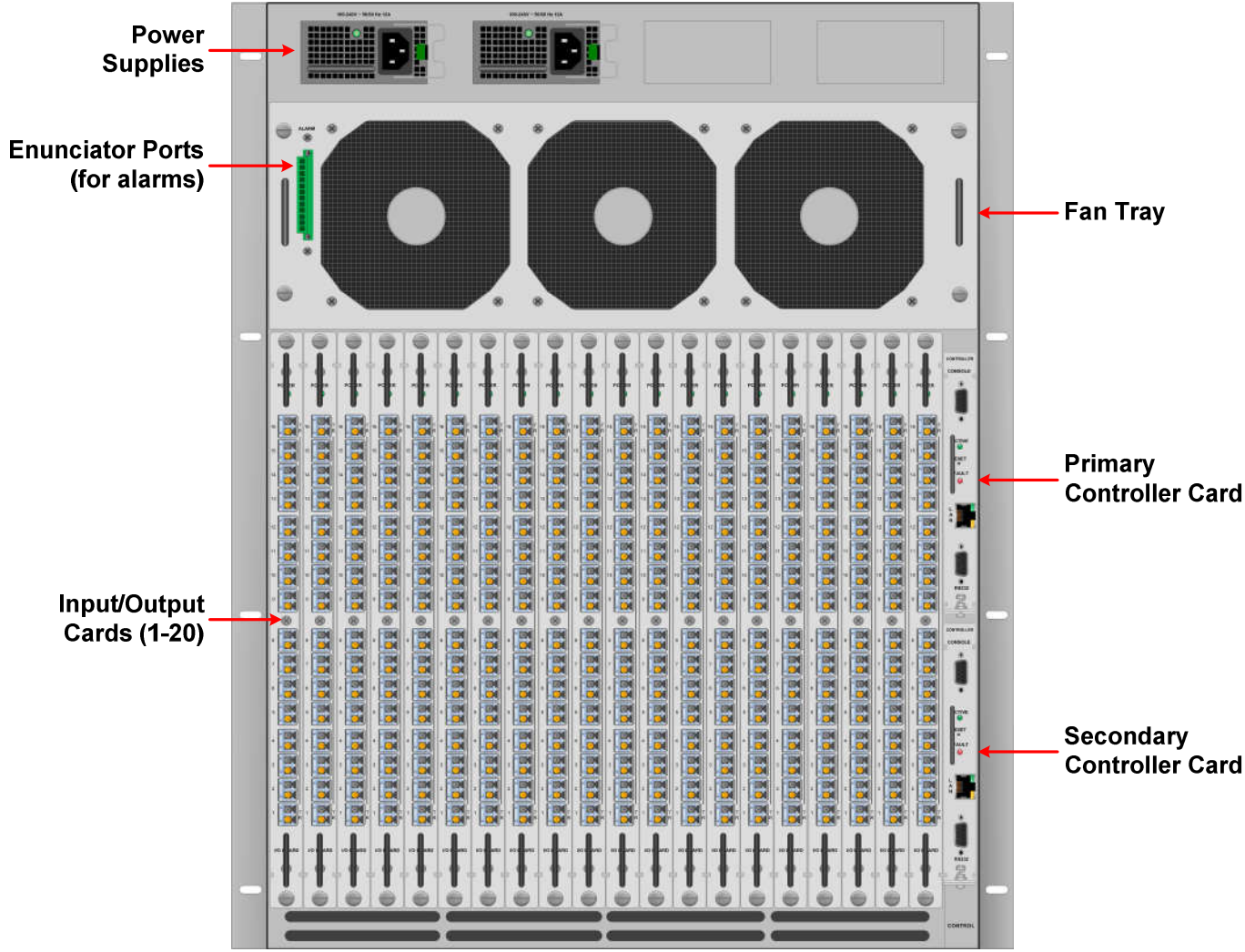

VX320VIDEO & VX320AUDIO Router – Rear View

Part 1: Hardware

Contents

When you receive your Thinklogical VX40 Router, you should find the following items:

- VX40 Chassis (includes 2 Power Modules, 1 Fan Tray Unit, and 1 Controller Card)
- Power Cords – (2) PWR-000006-R (International connections may differ)
- CAT5 Cable Assembly, 15 Feet – CBL000001-015FR
- Product Manual CD
- Product Quick Start Guide
- Chassis Options:
 - Redundant Controller Card – VXM-000005
 - Spare Fan Tray – VXM-000006
 - Spare Power Module(s) – VXM-000007
 - Data Upstream Card, 5 Ports – VXM-DI0005
 - Data Downstream Card, 5 Ports – VXM-DO0005

The VX40 ships configured to customer specifications. All physical connections to the product use industry-standard connectors.

If you ordered an EAL/4 certified unit, please verify that you have received the proper materials. The router should be labeled as VXR-000040 Rev B. This information is located on a sticker just inside the front door of your router along with the serial number information. Please also check that you have the correct version of the Velocity Matrix Router 40 Data Upstream Cards (VXM-DI0005 Rev A) and Velocity Matrix Router 40 Data Downstream Cards (VXM-DO0005 Rev A). This information is located on a sticker on the card with serial number information.

When you receive your Thinklogical VX80 Router, you should find the following items:

- VX80 Chassis (includes 2 Power Modules, 1 Fan Tray Unit, and 1 Controller Card)
- Power Cords – (2) PWR-000006-R (International connections may differ)
- CAT5 Cable Assembly, 15 Feet – CBL000001-015FR
- Product Manual CD
- Product Quick Start Guide
- Chassis Options:
 - Redundant Controller Card – VXM-000036
 - Spare Fan Tray – VXM-000006
 - Spare Power Module(s) – VXM-000007
 - Data Input/Output Card, 5 Ports – VXM-D00005

The VX80 ships configured to customer specifications. All physical connections to the product use industry-standard connectors.

If you ordered an EAL/4 certified unit, please verify that you have received the proper materials. The router should be labeled as VXR-000080 Rev B. This information is located on a sticker just inside the front door of your router along with the serial number information. Please also check that you have the correct version of the Velocity Matrix Router 80 Data Cards (VXM-D00005 Rev A). This information is located on a sticker on the card with serial number information.

When you receive your Thinklogical VX160 Router, you should find the following items:

- VX160 Chassis (includes 2 Power Modules, 1 Fan Tray Unit, and 1 Controller Card)
- Power Cords – (2) PWR-000056-R (International connections may differ)
- CAT5 Cable Assembly, 15 Feet – CBL000001-015FR
- Product Manual CD
- Product Quick Start Guide
- Chassis Options:
 - Fail-Over Controller Card – VXM-000001
 - Spare Fan Tray – VXM-000002
 - Spare Power Module(s) – VXM-000003
 - Data Upstream Card, 20 Ports – VXM-DI0020
 - Data Downstream Card, 20 Ports – VXM-DO0020

The VX160 ships configured to customer specifications. All physical connections to the product use industry-standard connectors.

If you ordered an EAL/4 certified unit, please verify that you have received the proper materials. The router should be labeled as VXR-000160 Rev B. This information is located on a sticker just inside the front door of your router along with the serial number information. Please also check that you have the correct version of the Velocity Matrix Router 160 Data Upstream Cards (VXM-DI0020 Rev B) and Velocity Matrix Router 160 Data Downstream Cards (VXM-DO0020 Rev B). This information is located on a sticker on the card with serial number information.

When you receive your Thinklogical VX320 Router, you should find the following items:

- VX 320 Chassis (includes 4 Power Modules, 1 Fan Tray Unit, and 1 Controller Card)
- Power Cords – (4) PWR-000056-R (International connections may differ)
- CAT5 Cable Assembly, 15 Feet – CBL000001-015FR
- Product Manual CD
- Product Quick Start Guide
- Chassis Options:
 - Fail-Over Controller Card – VXM-000008
 - Fail-Over Controller Card with OSD – VXM-000031*
 - Spare Fan Tray – VXM-000009
 - Spare Power Module(s) – VXM-000010
 - Data Input/Output Card, 16 Ports – VXM-D00016

The VX320 Router ships configured to customer specifications. All physical connections to the product use industry-standard connectors.

If you ordered an EAL/4 certified unit, please verify that you have received the proper materials. The router should be labeled as (VXR-000320 Rev A). This information is located on a sticker just inside the front door of your router along with the serial number information. Please also check that you have the correct version of the Velocity Matrix Router 320 Data Input/Output Cards (VXM-D00016 Rev A). This information is located on a sticker on the card with serial number information.

When you receive your Thinklogical VX320Video Router, you should find the following items:

- VX320Video Chassis (includes 2 Power Modules, 1 Fan Tray Unit, and 1 Controller Card)
- Power Cords – (2) PWR-000056-R (International connections may differ)
- CAT5 Cable Assembly, 15 Feet – CBL000001-015FR
- Product Manual CD
- Product Quick Start Guide
- Chassis Options:
 - Fail-Over Controller Card – VXM-000018
 - Fail-Over Controller Card with OSD – VXM-000032*
 - Spare Fan Tray – VXM-000009
 - Spare Power Module(s) – VXM-000010
 - Data Input/Output Re-timer Card, 16 Ports – VXM-D00T16

The VX320Video Router ships configured to customer specifications. All physical connections to the product use industry-standard connectors.

***OSD (On Screen Display) is available with our X4 Configurator Control Management System.**

If you ordered an EAL/4 certified unit, please verify that you have received the proper materials. The router should be labeled as (VXR-V00320 Rev A). This information is located on a sticker just inside the front door of your router along with the serial number information. Please also check that you have the correct version of the Velocity Matrix Router 320Video Data Input/Output Re-timer Cards (VXM-D00T16 Rev A). This information is located on a sticker on the card with serial number information.

When you receive your Thinklogical VX320Audio Router, you should find the following items:

- VX320Audio Chassis (includes 2 Power Modules, 1 Fan Tray Unit, and 1 Controller Card)
- Power Cords – (2) PWR-000056-R (International connections may differ)
- CAT5 Cable Assembly, 15 Feet – CBL000001-015FR
- Product Manual CD
- Product Quick Start Guide
- Chassis Options:
 - Fail-Over Controller Card – VXM-000024
 - Spare Fan Tray – VXM-000009
 - Spare Power Module(s) – VXM-000010
 - Data Input/Output Re-timer Card, 16 Ports – VXM-A00T16

The VX320Audio Router ships configured to customer specifications. All physical connections to the product use industry-standard connectors.

If you ordered an EAL/4 certified unit, please verify that you have received the proper materials. The router should be labeled as (VXR-A00320 Rev A). This information is located on a sticker just inside the front door of your router along with the serial number information. Please also check that you have the correct version of the Velocity Matrix Router 320Audio Data Input/Output Re-timer Cards (VXM-A00T16 Rev A). This information is located on a sticker on the card with serial number information.

VX Router Modules

The inspired modular approach of the VX40, VX80, VX160, VX320 and VX320Video/Audio Routers makes all critical system components, including power supplies, cooling fans and pluggable optics (SFP+), hot-swappable, thus minimizing productivity impact in case of failure or system reconfiguration.

Power Supplies

The dual, redundant power supplies ensure continuous, uninterrupted power. The supplies are current sharing, which means the supplies equally share the load. If a power supply were to fail, a single power supply can withstand the entire current load of the VX Router system. Although the VX Routers functions properly with one power module, it is recommended that both modules be used, preferably connected to two independent power sources (for redundancy). Additionally, the hot-swappable feature allows for easy replacement of a module (in case of failure) without interrupting the VX Routers system functionality.

Fan Tray and Alarms

The VX Routers use 3 DC cooling fans, all located in one modular fan tray. The tray is designed to move air horizontally through the enclosure. This hot-swappable fan tray allows easy replacement of the module without interrupting the system functionality. Any two of the three DC fans will adequately cool the system.

The Fan Tray is also equipped with an Alarm Annunciator Port. The system alarms can be configured to trigger an external control system or generate SNMP Traps.

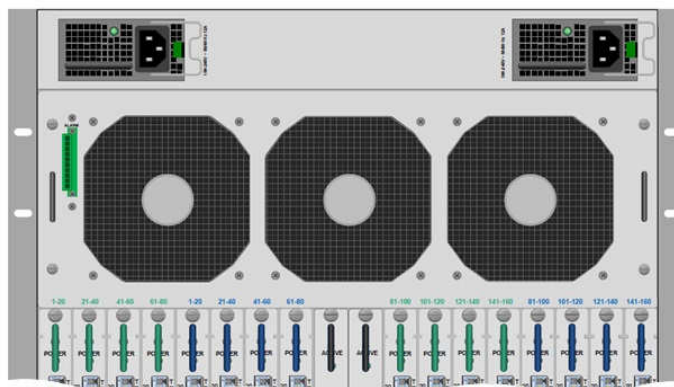

VX Router Power Supplies and Fan Tray with Alarm Annunciator

The VX Routers Critical Hardware Alarms are as follows:

The VX40, VX80 & VX160 Routers Critical Hardware Alarms:

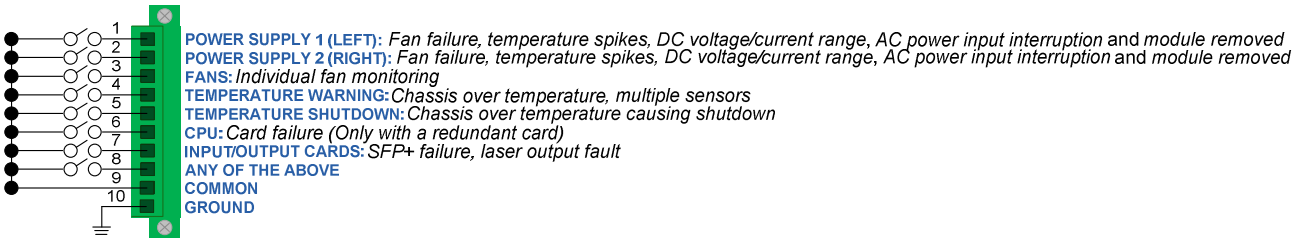

The VX320VIDEO/AUDIO Router Critical Hardware Alarms:

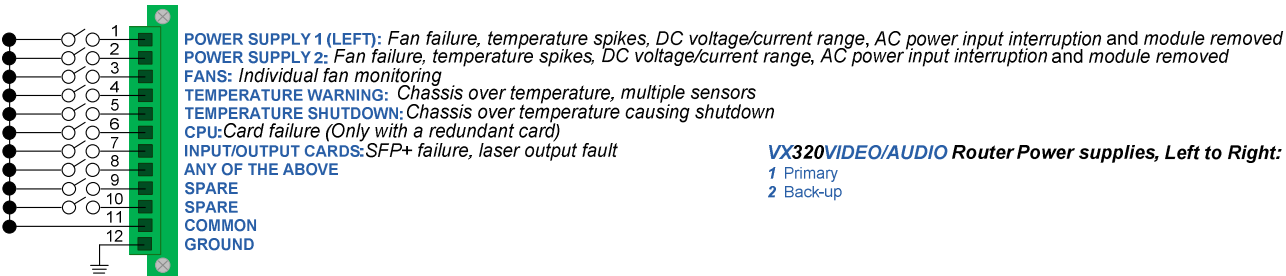

VX320VIDEO/AUDIO Router Power supplies, Left to Right:
 1 Primary
 2 Back-up

The VX320 Router Critical Hardware Alarms:

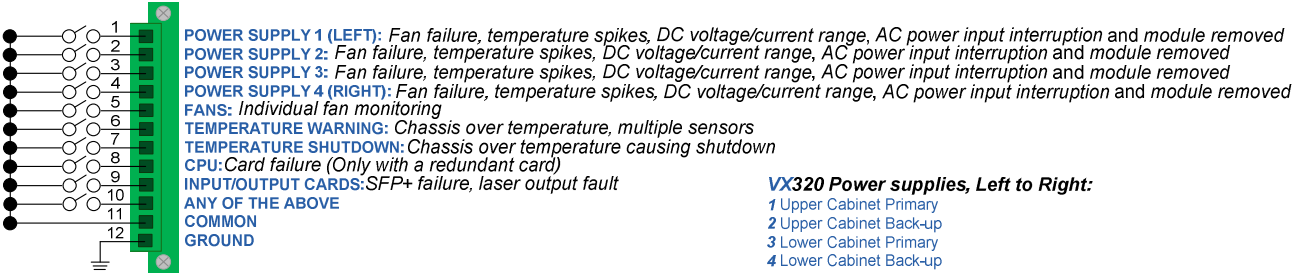

VX320 Power supplies, Left to Right:
 1 Upper Cabinet Primary
 2 Upper Cabinet Back-up
 3 Lower Cabinet Primary
 4 Lower Cabinet Back-up

Alarm Descriptions for the VX40, VX160, VX320 and VX320Video/Audio

Adjustable Air Vents for the VX160

If the VX160 is mounted in a rack that restricts the front air intake, additional vents are located at the bottom, rear of the VX160 chassis. Thumb screws open or close these vents to adjust air flow.

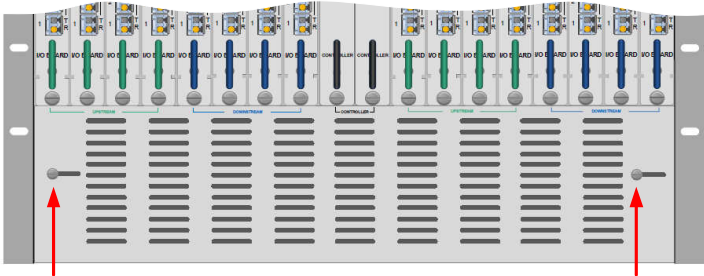

The Controller Cards

The hot-swappable Controller Card connects the Router to an external Linux or Windows CPU. The serial port can also be used for 3rd party controller integration (such as Crestron, AMX or home-spun interfaces). Also, the *X4 Configurator Software* can be used to control the Router via the LAN port. Please note that there is a separate document for our X4 Configurator Manual. It can be found on our website at www.thinklogical.com. The VX320 and VX320VIDEO Routers require an OSD (On Screen Display) version of the Controller Card for use with the X4 Configurator: VXM-000031 (VX320) and VXM-000032 (VX320VIDEO).

ACTIVE:
LED is ON= Controller Card is active
LED is OFF= Controller Card is in standby or has failed

USB Port: Reserved

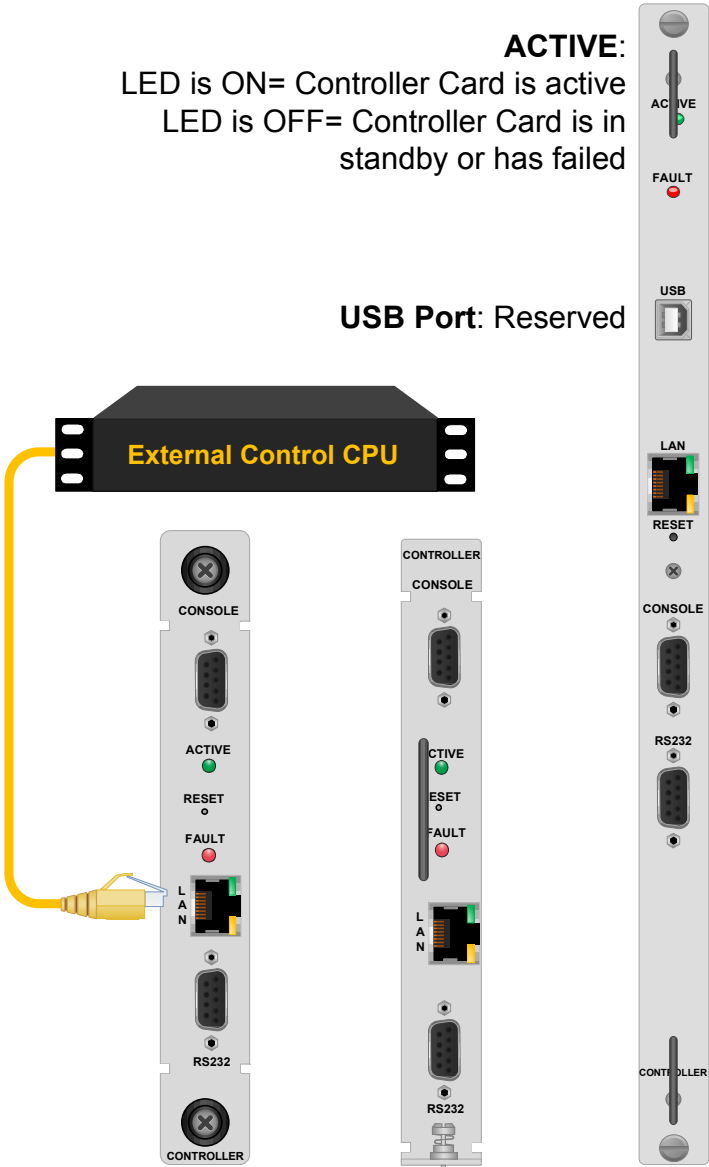

CONSOLE PORT: Local debug

RESET: Resets the CPU
FAULT: LED is ON= Card Failure

LAN: Connection to external CPU (RJ45)

RS232: ASCII Control Interface

VX40/

VX80

VXM-000005

VX320

VXM-000008

VX160

VXM-000001

External CPU to Controller Cards

The Controller Cards of each VX Router model connect the Router to an External CPU.

The External Control CPU must meet the following minimum requirements:



- RedHat EL5.3 or Windows or CentOS 5.3
- 1 Gig RAM
- 1 DVD drive
- VGA and/or DVI video port
- USB or PS2 Keyboard / Mouse
- 1 network port
- 80 Gig (minimum) hard drive
- 1 optional RS-232 serial port (Crestron/AMX serial access)

An optional **Back-Up Controller Card** ensures uninterrupted functionality if the Primary Controller Card ever needs to be replaced.

If the VX Router is to be controlled via Ethernet, it will require a static IP address. This value can be set via the DIP switch to the values listed below. **The factory default setting is 192.168.13.15.**

VXRouter DIP Switch Locations

VXVIDEO or AUDIO 320 Router with front cover removed

VX160 Router with front cover removed

VX320 Router with front cover removed

VX80 Router with front cover removed

VX40 Router with front cover removed

8 Position DIP Switch (Located on the lower left of the backplane on most VX Router models)

								Primary Controller IP Addresses		Back-up Controller IP Address
8	7	6	5	4	3	2	1			
0	0	0	0	0	0	0	0	192.168.13.15 & 192.168.13.115	192.168.13.16	
0	0	0	0	0	0	0	1	192.168.13.17 & 192.168.13.117	192.168.13.18	
0	0	0	0	0	0	1	0	192.168.13.19 & 192.168.13.119	192.168.13.20	
0	0	0	0	0	0	1	1	192.168.13.21 & 192.168.13.121	192.168.13.22	
0	0	0	0	0	1	0	0	192.168.13.23 & 192.168.13.123	192.168.13.24	
0	0	0	0	1	0	0	1	192.168.13.25 & 192.168.13.125	192.168.13.26	
0	0	0	0	1	1	0	0	192.168.13.27 & 192.168.13.127	192.168.13.28	
0	0	0	0	1	1	1	0	192.168.13.29 & 192.168.13.129	192.168.13.30	
0	0	0	1	0	0	0	0	192.168.13.31 & 192.168.13.131	192.168.13.32	
0	0	0	1	0	0	1	0	192.168.13.33 & 192.168.13.133	192.168.13.34	
0	0	0	1	0	1	0	0	192.168.13.35 & 192.168.13.135	192.168.13.36	
0	0	0	1	0	1	1	0	192.168.13.37 & 192.168.13.137	192.168.13.38	
0	0	0	1	1	0	0	0	192.168.13.39 & 192.168.13.139	192.168.13.40	
0	0	0	1	1	0	1	0	192.168.13.41 & 192.168.13.141	192.168.13.42	
0	0	0	1	1	1	0	0	192.168.13.43 & 192.168.13.143	192.168.13.44	
0	0	0	1	1	1	1	0	192.168.13.45 & 192.168.13.145	192.168.13.46	

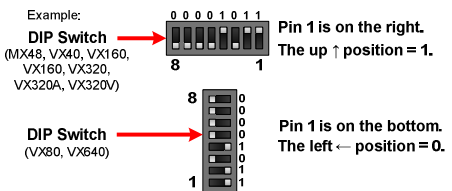

VX Router DIP Switch Locations and Setting

The simplest network connection is an isolated network with only the VX Router, the control server, and any control clients using static IP addresses. The VX Router can be set to any of the above settings. The control server must be at **192.168.13.9**, and the control clients could then be set to any other addresses in the **192.168.13.X** family.

If static IP addresses for the control server and its clients are not possible, then the control server will require two (2) network interfaces with one interface set to the static address **192.168.13.9** and dedicated to the VX Router(s) while the other network interface can be configured as required by the facility's network administrator.

A **Back-Up Controller Card is optional** to ensure uninterrupted functionality if the Primary Controller Card should fail or need to be replaced. The Primary Controller Card should always be in the left or upper controller slot. This card must have a LAN connection that allows communication between the Primary Controller and a server having an IP address of **192.168.13.9**. Without this interface, the back-up controller cannot take control of the router. The server should have its firewall turned off or be configured so that it is able to respond to pings from the Primary and back-up controllers.



Note: Removing the Primary Controller Card when it is Active will power down the VX Router and interrupt service. Refer to page 36 “How to Install or Replace a Controller Card”.



Note: When using a Back-up Controller configuration in a Secure Application with Restricted Switching, both controllers must have the same Restricted Switching Table files (see Appendix D: Secure Applications, pages 56-66).

Input/Output Cards

The hot-swappable Input/Output (I/O) cards provide excellent in-service expansion capabilities in convenient sets of **5 ports per I/O card** for the VX40 and VX80, sets of **20 ports per I/O card** for the VX160 or sets of **16 ports per I/O card** for the VX320, thus allowing re-configuration without interrupting signal processing.

Each I/O card consists of one Transmit (T) and one Receive (R) optic per port. I/O Cards are available with LC-type fiber connectors and can be assembled with Single-mode or Multi-mode optics (SFP+). Each individual I/O Card lists the ports as 1 through 5 on the VX40 and VX80, as 1 through 20 on the VX160 and as 1 through 16 on the VX320 and VX320Video/Audio. The Fan Tray module lists the port numbers

(All numbering is bottom to top, left to right. See **Input/Output Port Numbering** beginning on page 25). A LED located at the top of each I/O card indicates when power is ON to that card.

VX40 I/O Cards

The VX40 Router consists of a single 80 input by 80 output non-blocking switch matrix. This allows any port on any I/O card (Upstream or Downstream) to be connected to any other port. The VX40 is designed so that 8 I/O card slots on the left side are used for Upstream Cards and 8 I/O card slots on the right side are used for Downstream Cards.

The Upstream and Downstream Cards are functionally equivalent. Either card can be used interchangeably for routing signals, but they can only physically plug into their respective slots in the VX40 chassis. Thus, the VX40 can connect any Upstream Port optical input or any Downstream Port optical input (SFP+ R) to any Upstream and/or any Downstream Port optical output (SFP+ T). **Figure 1** below depicts a bi-directional connection from Upstream Port 1 to Downstream Port 1. This requires two switch connections, one from the Upstream optical input to the Downstream optical output and one from the Downstream optical input to the Upstream optical output.

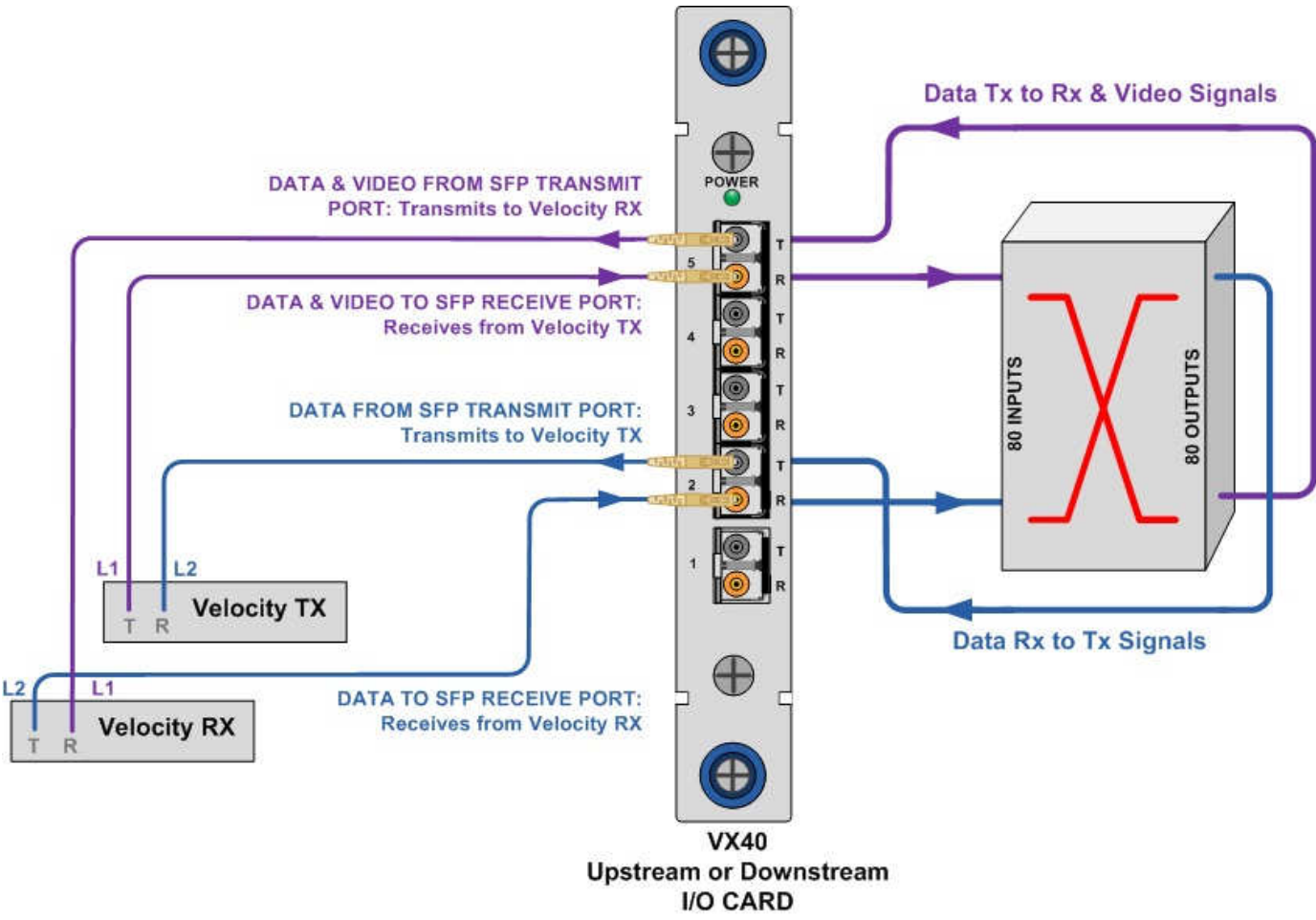

Figure 1: VX40 Input/Output Concept

VX80 I/O Cards

The VX80 Router consists of a single 80 input by 80 output non-blocking switch matrix. This allows any port on any I/O card to be connected to any other port. The VX80 is designed so that all 16 I/O card slots accept the same type of card. The VX80 I/O card is functionally and physically the same as the VX40 Upstream Card. The VX80 Router configuration can have a minimum of one I/O Card. Each VX80 I/O card contains 5 ports, so that when fully configured, the VX80 will contain 16 I/O cards. The 16 I/O cards provide a total of 80 Optical Input/Output connections (SFP+ T/R). The switching matrix connects any optical input (SFP+ R) to any optical output (SFP+ T), even if it is the same Port number (i.e. Port 1 R connected to Port 1 T).

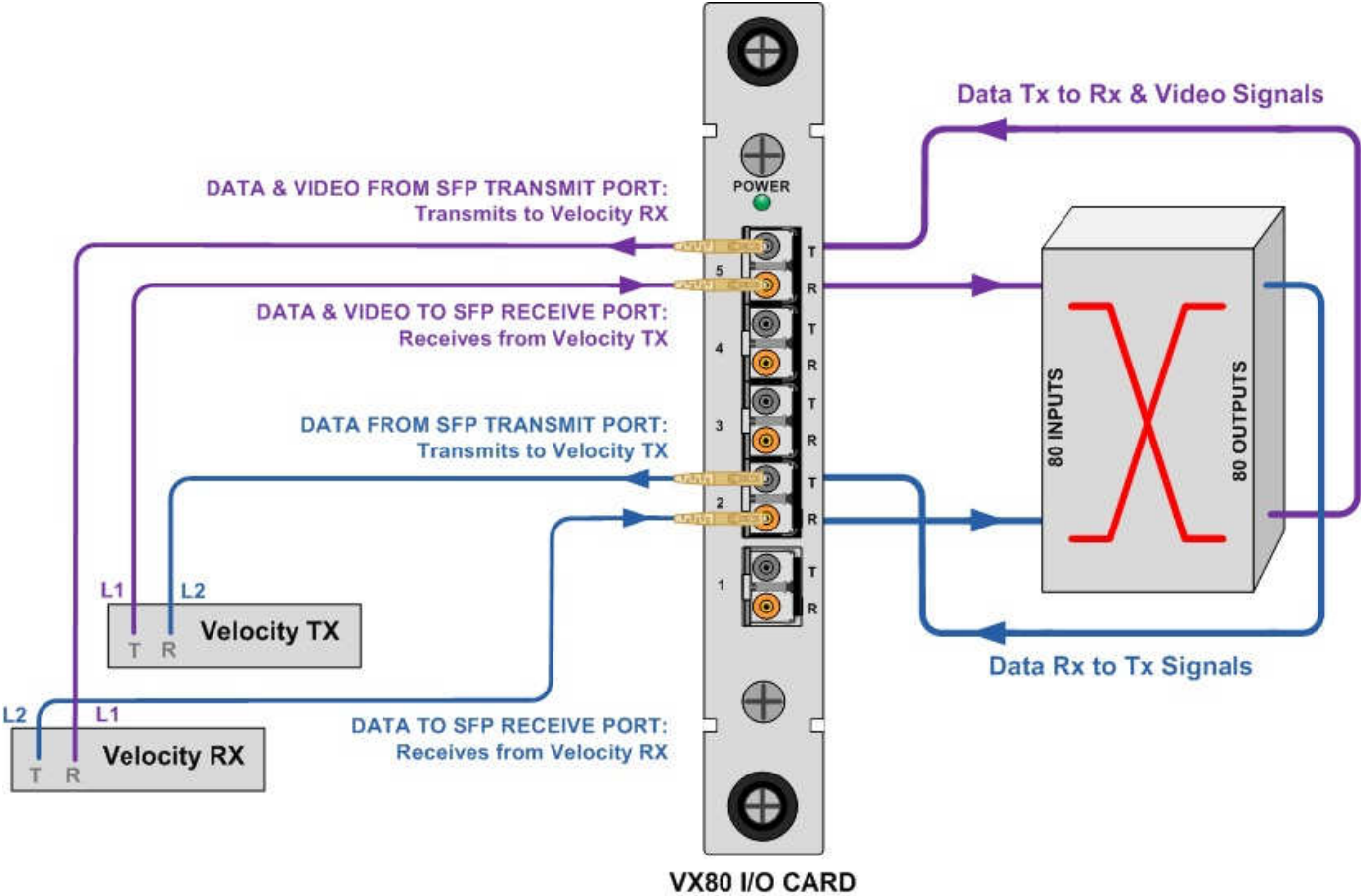

Figure 2: VX80 Input/Output Concept

VX160 I/O Cards

The VX160 contains two independent 160x160 fully non-blocking switch matrices. One switching matrix connects any Upstream Port optical input (SFP+ R) to any Downstream Port optical output (SFP+ T). The other switching matrix connects any Downstream Port optical input (SFP+ R) to any Upstream Port optical output (SFP+ T). The VX160 Router configuration must have a minimum of 1 Upstream Card (Green) and 1 Downstream Card (Blue), each containing 20 ports. When fully configured, the VX160 will contain 8 Upstream cards and 8 Downstream cards. The 8 Upstream cards provide a total of 160 Optical Input/Output connections (SFP+ T/R) described as Upstream Ports 1-160. The 8 Downstream cards provide a total of 160 Optical Input/Output connections (SFP+ T/R) described as Downstream Ports 1-160. **Figure 3** depicts a bidirectional connection from Upstream Port 1 to Downstream Port 1, showing downstream flow through one 160x160 fully non-blocking switch matrix, and upstream flow through another 160x160 fully non-blocking switch matrix.

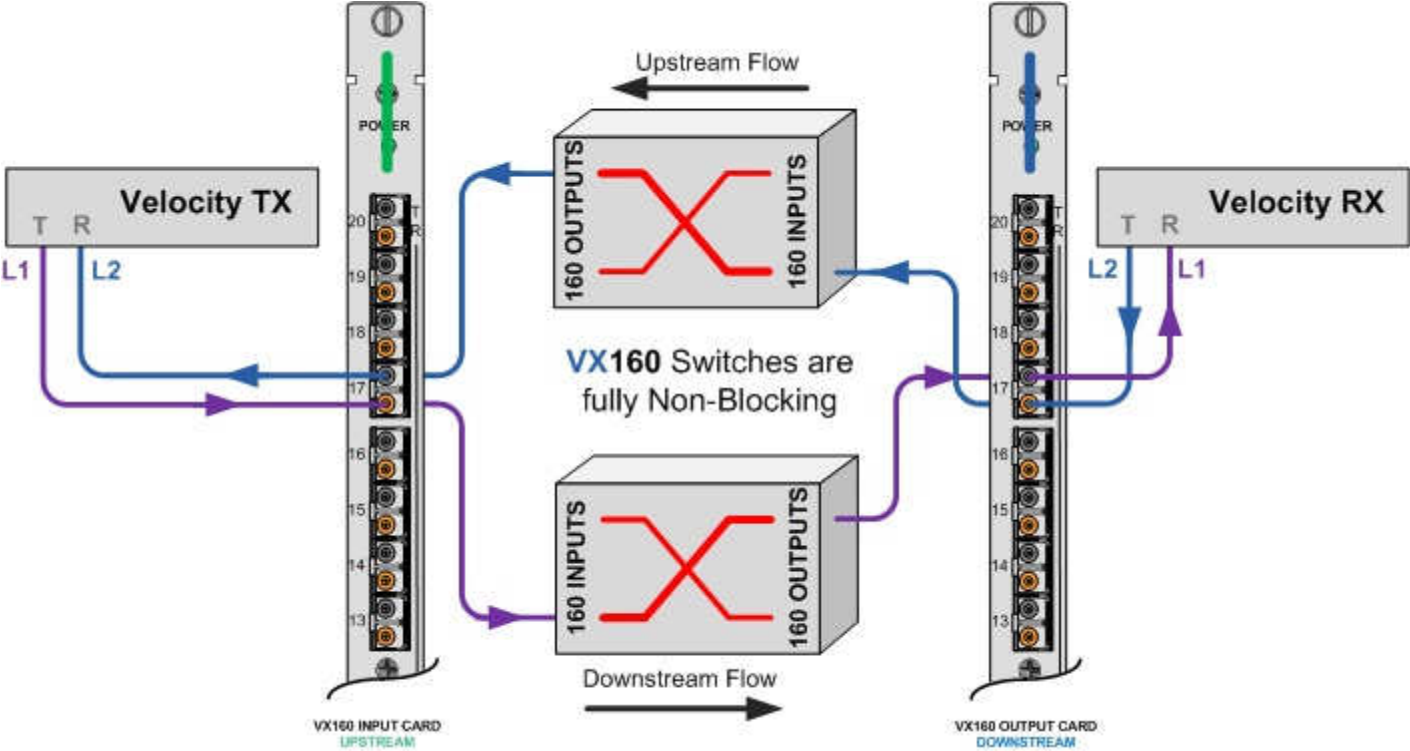

Figure 3: VX160 Input/Output Concept

VX320 I/O Cards

The VX320 Router configuration can have a minimum of one I/O Card in either the Upper Card Cage or the Lower Card Cage. The VX320 Router is constructed with one fully non-blocking 320x320 switch matrix in the Upper Card Cage and another fully non-blocking 320x320 switch matrix in the Lower Card Cage. Each VX320 I/O card contains 16 ports, so that when fully configured, the VX320 will contain 20 I/O cards in the Upper Card Cage and 20 I/O cards in the Lower Card Cage. The 20 I/O cards in the Upper Card Cage provide a total of 320 Optical Input/Output connections (SFP+ T/R) described as Upper Card Cage Ports 1-320.

Similarly, the 20 I/O cards in the Lower Card Cage provide a total of 320 Optical Input/Output connections (SFP+ T/R) described as Lower Card Cage Ports 1-320. The Upper Card Cage switching matrix connects any Upper Card Cage Port optical input (SFP+ R) to any Upper Card Cage Port optical output (SFP+ T), even if it is the same Port number (i.e. Port 1 R connected to Port 1 T). Similarly, the Lower Card Cage switching matrix connects any Lower Card Cage Port optical input (SFP+ R) to any Lower Card Cage Port optical output (SFP+ T), even if it is the same Port number (i.e. Port 1 R connected to Port 1 T).

Figure 4 depicts a bidirectional connection. One direction is the connection from the Upper Card Cage Port optical input (SFP+ R) to the Upper Card Cage Port optical output (SFP+ T), showing Video/Data flow from the TX to the RX being routed through the Upper Card Cage 320x320 fully non-blocking switch matrix. The other direction is the connection from the Lower Card Cage Port optical input (SFP+ R) to the Lower Card Cage Port optical output (SFP+ T), showing the Data (KMASS) flow from the RX to the TX being routed through the Lower Card Cage 320x320 fully non-blocking switch matrix.

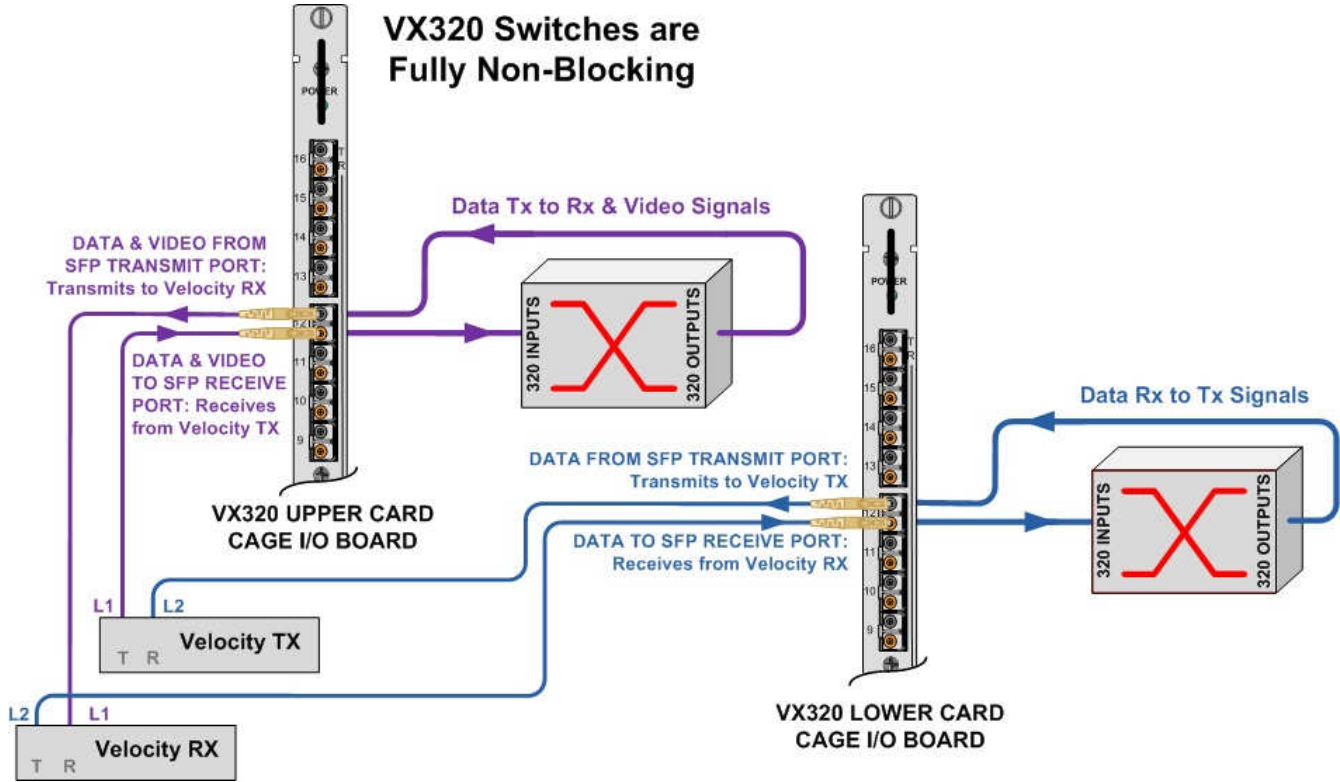
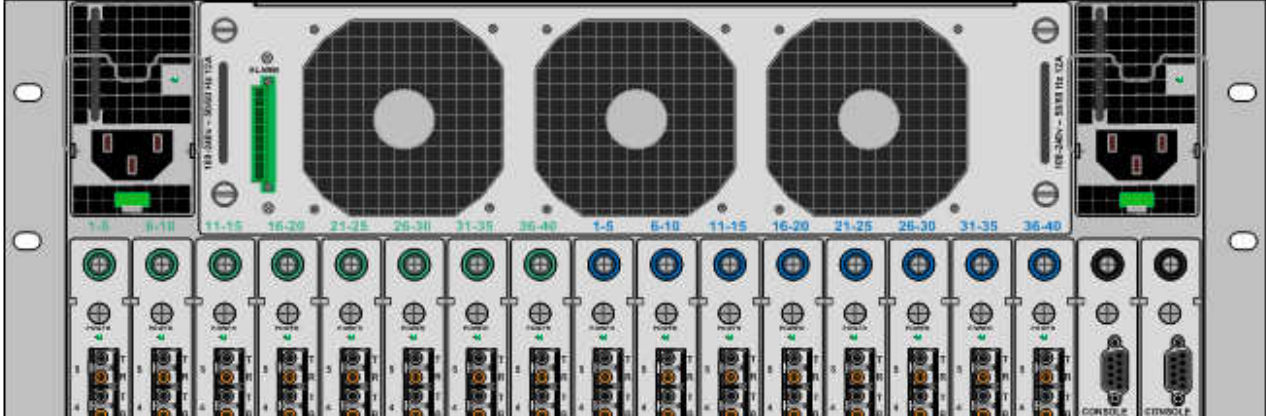

Figure 4: VX320 Input/Output Concept

Input/Output Port Numbering

VX40 Input / Output Port Numbering



VX80 Input / Output Port Numbering

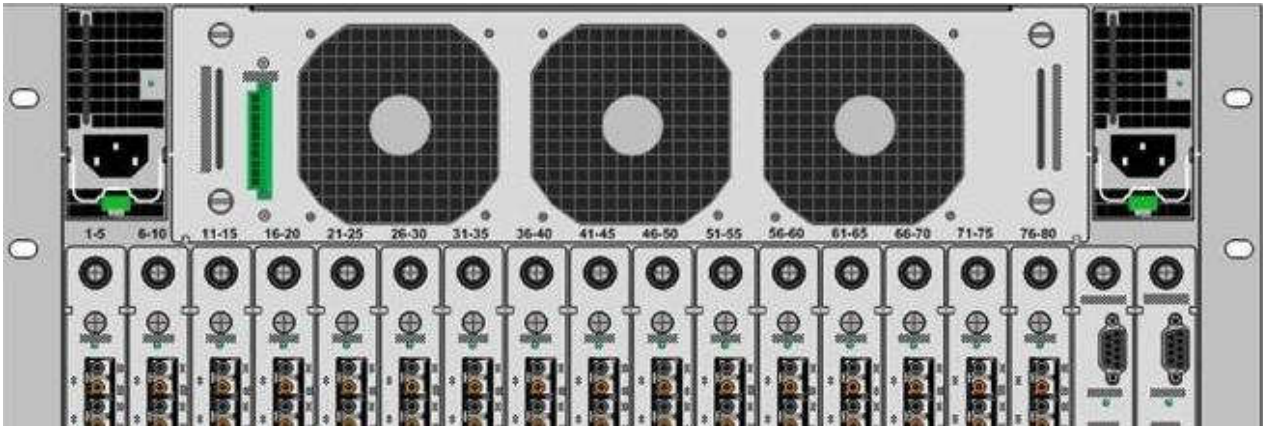

VX160 Input / Output Port Numbering

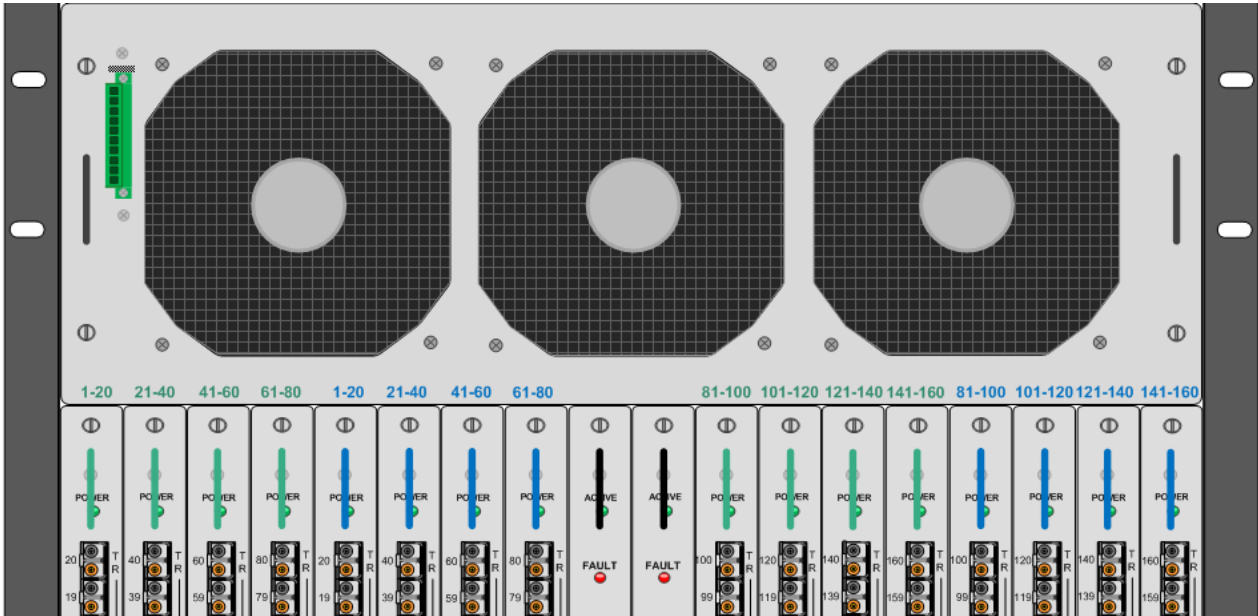

VX320 and VX320Video/Audio I/O Board Port Numbering (Same for Upper & Lower Card Cages)

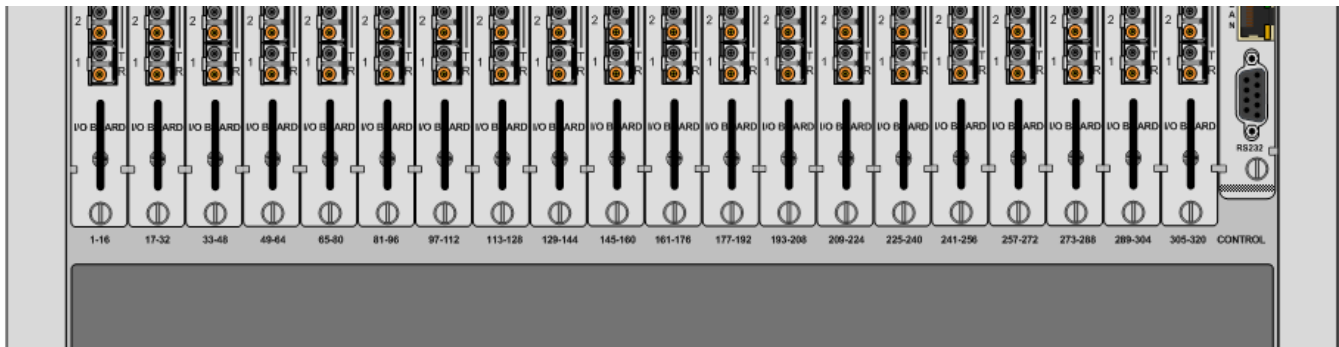

Pluggable SFP+ Optical Modules

The SFP+ Optical Module is an 8Gb/s Short-Wavelength Transceiver designed for use in bi-directional Fiber Optic Channel links. The modules are hot-pluggable and operate with 3.3VDC.

Each Input and Output card contains rows of SFP+ modules that serve as the fiber-optic couplers for the fiber cables to and from the Thinklogical Tx and Rx Extenders. Individual cards can be removed for ease of access to the SFP+ modules.

Each I/O card can have as many as 5 SFP+ modules for a VX 40, 20 SFP+ modules for a VX 160, and 16 SFP+ modules for a VX 320 each mounted within a grounded metal enclosure. Each SFP+ module is locked into its enclosure with a built-in latch handle that can be opened for removal or locked for installation.

The latch handle spans the two LC ports and arrows printed on the handle indicate which port is an INPUT (▲) and which is an OUTPUT (▼).

Always use dust caps to protect against damage when any fiber optic connector is not attached to its coupling device.



SFP+ Module



SFP+ with latch open



Dust plug in unused SFP+.



Note: It is good practice to immediately install dust plugs in unused SFP modules and on the ferrules of unconnected fiber-optic cables.

Fiber Optic Cable

Fiber Optic Cable Requirements

Thinklogical recommends SX+ Laser Enhanced (50µm) fiber for your VX Router and Velocity Extension System. Multi-mode fiber has the ability to extend up to a maximum of 1000m, where Single-mode fiber has the ability to extend distances beyond 1000m.

STOP **Warning!** Do not use APC (Angle Physical Contact) Connectors! If inserted into an SFP+, APCs may damage the SFP+.

Handling Fiber Optic Cable

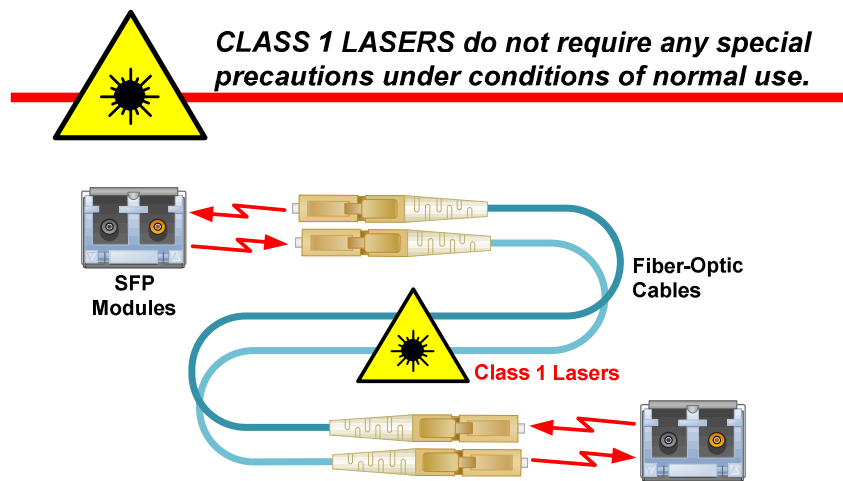

Unlike copper cabling, fiber optic cable requires special handling. A small bit of dust or a scratch on the ferrule tip can attenuate the optical signal so that it becomes unusable.

STOP **Warning!** The ends of the connectors (the ferrule) should never come in contact with any foreign object, including fingertips.

STOP **Warning!** Minimum bend radius must be 3". Be careful not to pinch or kink the fiber when using ties.

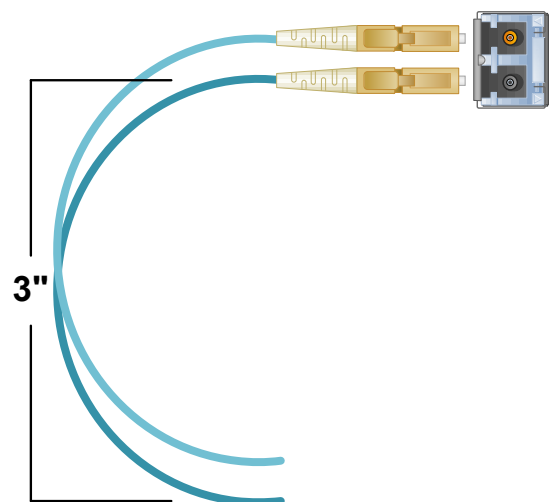

Installing Fiber into Input/Output Cards

Step 1: Grasp the LC connector of the fiber optic cable by the sides and remove the dust cap.



Warning! Laser in use! Do not look directly into the opening.

Step 2: Carefully insert the fiber connector into the SFP+ port until it locks into place.

Removing Fiber from Input/Output Cards

Step 1: The LC connector has a locking feature that can be released by depressing the latch-release tab located on the top of the connector. With the tab depressed, slowly remove the cable by pulling the connector straight out of the SFP+ port.



Warning! Laser in use! Do not look directly into the opening.

Step 2: Immediately install a dust cap on the ferrule to protect the fiber tip and install a dust cap into the SFP if another fiber is not immediately installed.

Connecting to Thinklogical Velocity Extenders

VX Routers are designed to work with any Thinklogical product designed with the MRTS technology (e.g. Velocity Extenders). VX Routers and Velocity Extenders are a new, unique class of cost-effective matrix switching and KVM extension designed for a variety of high-performance computing environments. Comprised of a fiber-in, fiber-out matrix switch and a fiber-optic KVM extender (with a transmitter and receiver), this complete system provides transparent and secure routing, switching and extension of video and high-speed data peripherals to remote destinations with ease.

BEFORE STARTING ANY PROCEDURE, IT IS RECOMMENDED THAT YOU READ THE INSTRUCTIONS THOROUGHLY!

Connecting to the Receiver

The Velocity Receiver serves as the Destination (desktops, theaters, conference rooms, editing suites, control consoles, video walls, etc). Depending on your configuration, your KMASS devices (audio, keyboard, mouse, etc) are first connected to the Receiver using standard cables. Power can then be supplied to the unit. The Receiver then connects to the VX Router SFP+ ports using fiber (Multi-mode fiber for distances up to 1000m; Single-mode fiber for distances beyond 1000m).

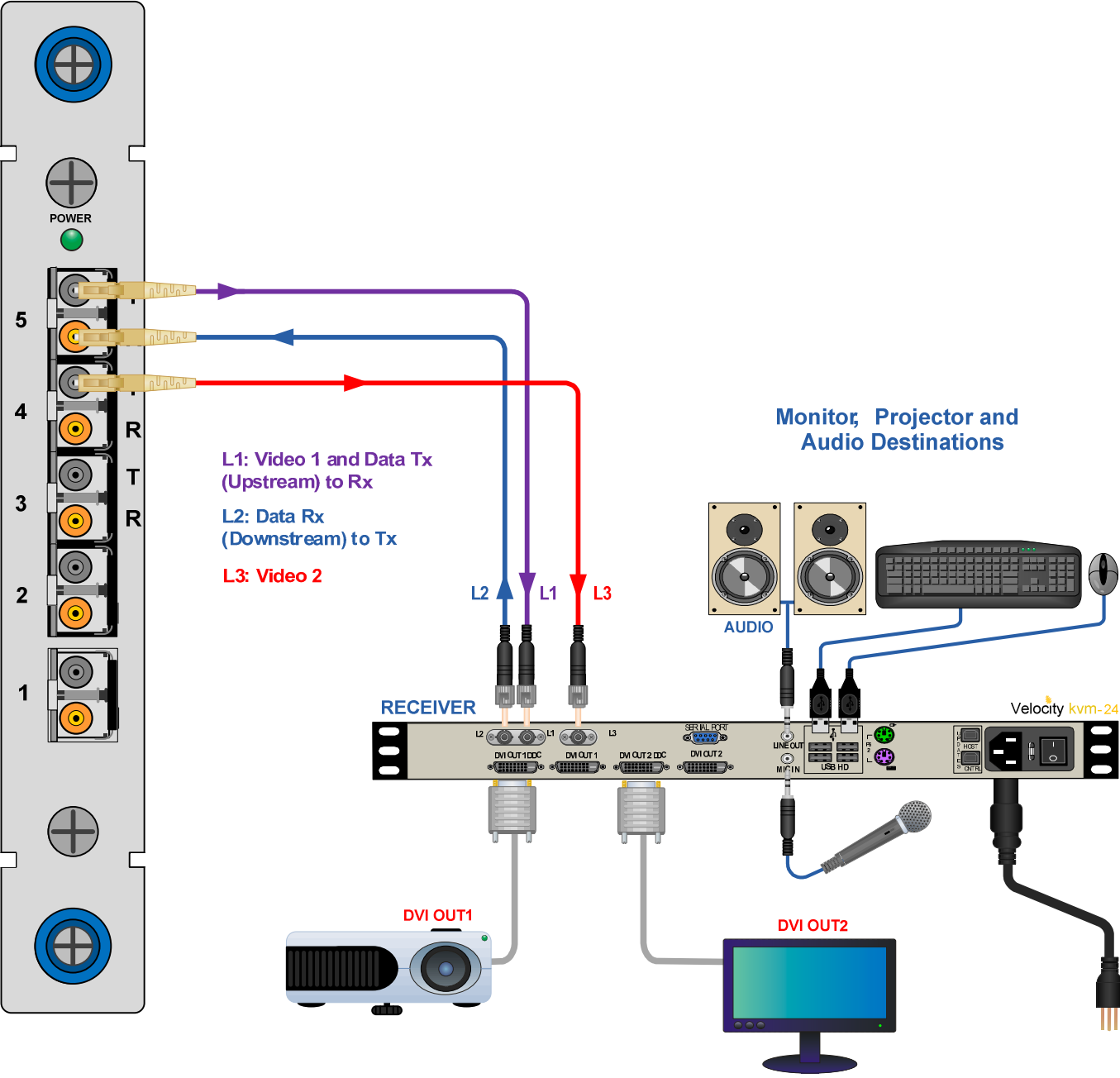

Connecting the Thinklogical VelocityKVM-24 Extender Receiver to the VX40/VX80

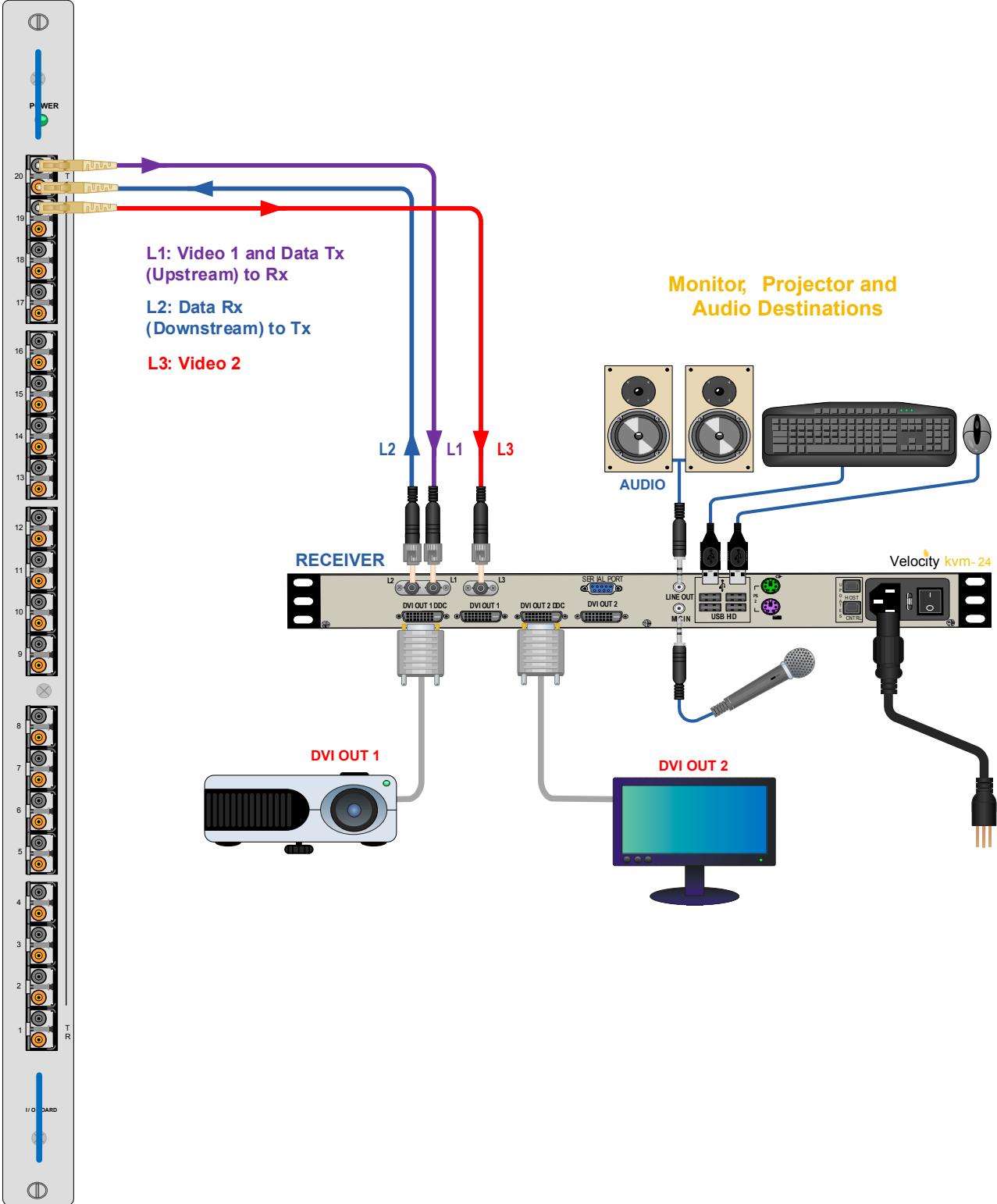

Connecting the Thinklogical VelocityKVM-24 Extender Receiver to the VX160

Connecting to the Transmitter

The Transmitter serves as the Source (computer and video entities). Depending on your configuration, your local KMASS devices (keyboard, mouse, etc) are first connected. The video sources (e.g. computers) are then connected followed by any local video devices. Power can then be supplied to the unit. The Transmitter connects to the VX160 Upstream ports using fiber (Multi-mode fiber for distances up to 1000m; Single-mode fiber for distances beyond 1000m).

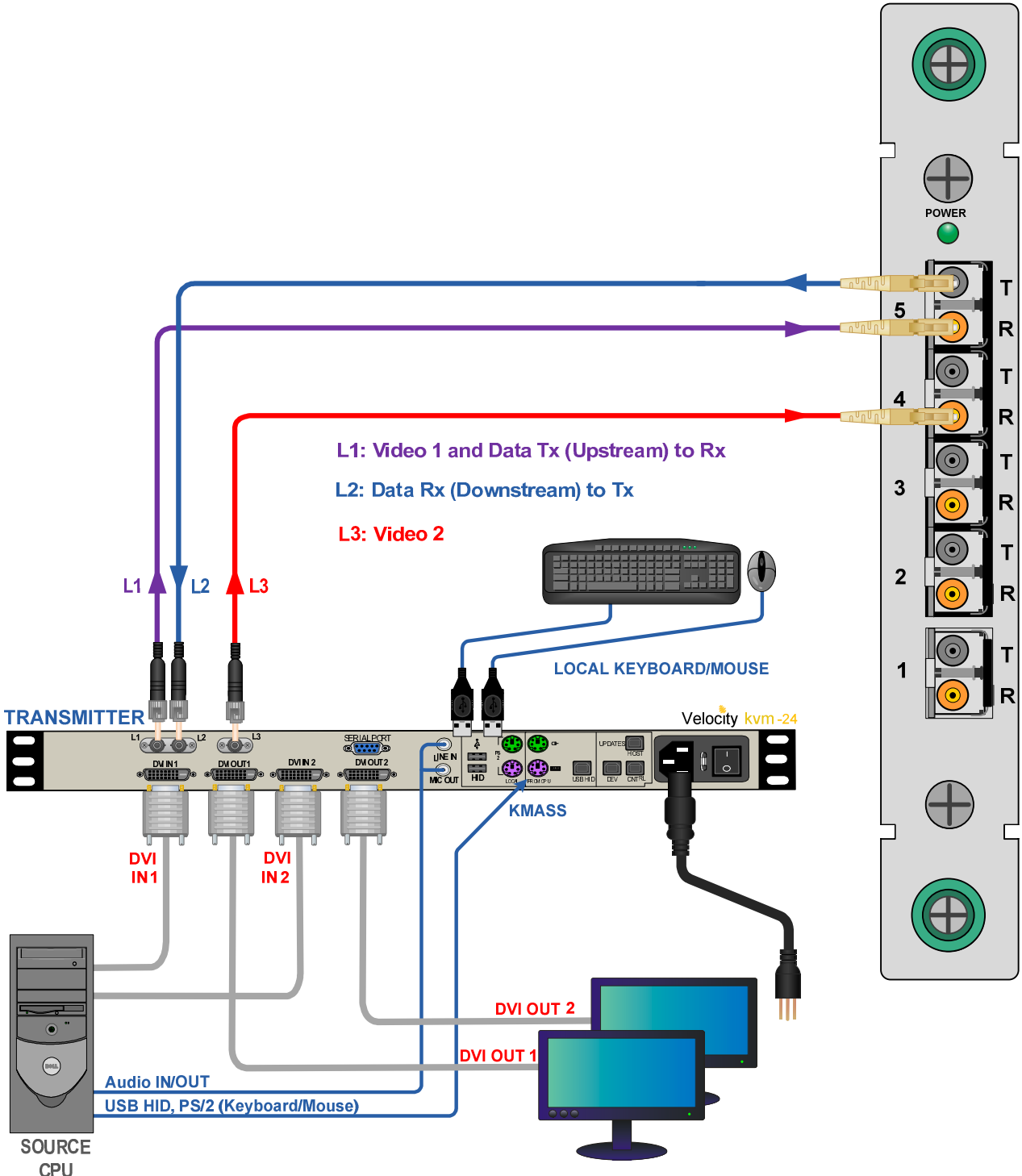

Connecting the Thinklogical VelocityKVM-24 Extender Transmitter to the VX40/VX80

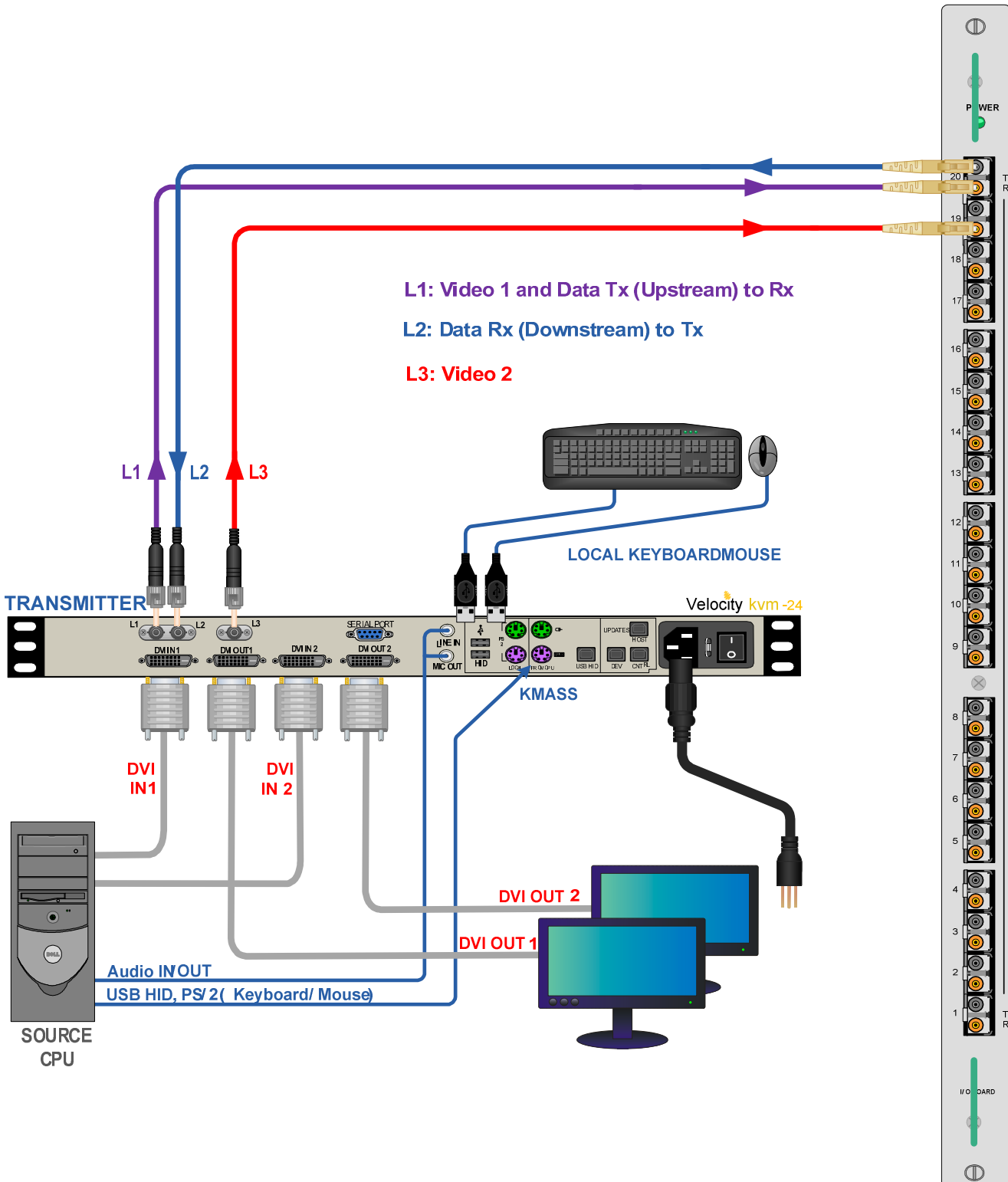

Connecting the Thinklogical VelocityKVM-24 Extender Transmitter to the VX160

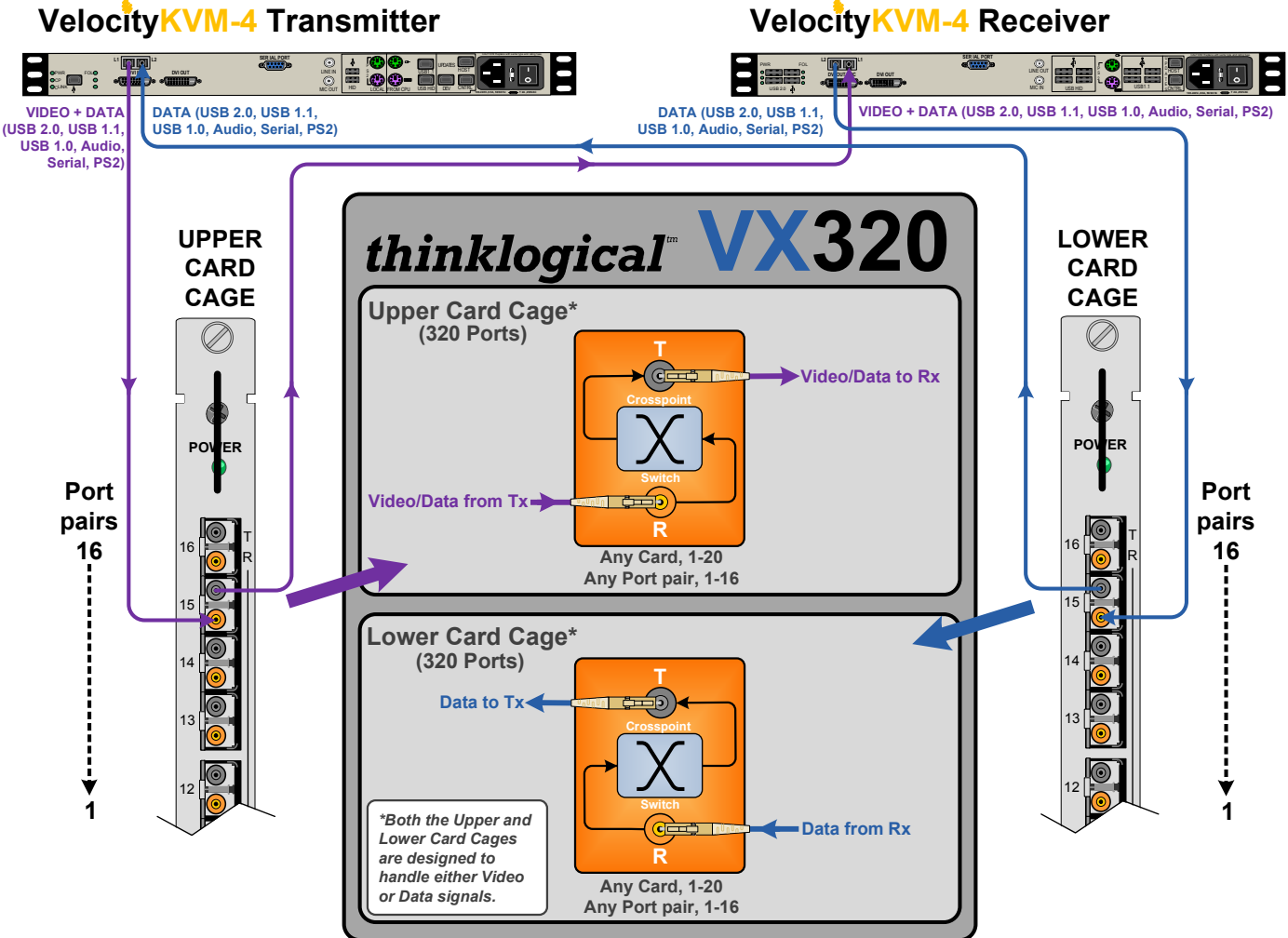

Connecting the Thinklogical VelocityKVM-4 Extender Transmitter and Receiver to the VX320

Installation

All physical connections to the product use industry-standard connectors. Non-supplied cables that may be needed are commercially available. All connections are found on the rear of the unit.

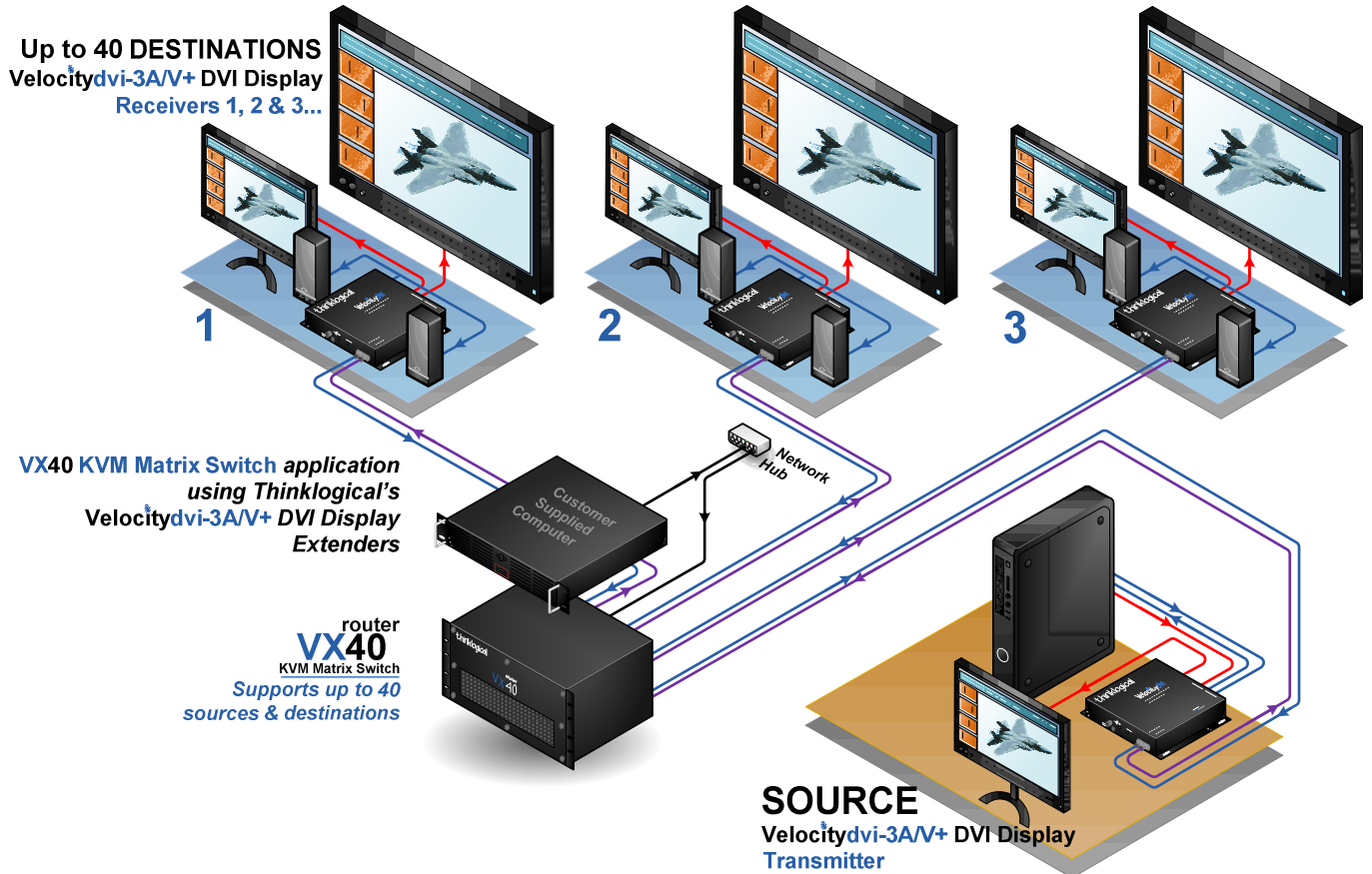

Typical VX40 Router Application using VelocityDVI-3AV+ Extenders

Set-Up



Note: Insure that all thumb screws are finger tight so that all the modules are properly held in the chassis.

1. Carefully remove the VX Router from its shipping container. Inspect the VX Router to make certain that no damage occurred during shipment.
2. All of the I/O cards are installed at the factory to meet the customer's specified configuration. Insure that the I/O cards are properly seated in the unit. All of the I/O cards have thumb screw retainers. All SFP+ Modules should have a dust plug installed. Leave them in until that port is used. (Retain them for later use.)
3. After checking the I/O cards, inspect the top of the unit. There are two (VX40, 80, 160) or four (VX320 & 320Video/Audio) power supplies located in the top part of the chassis. Verify that the power supplies are secure in the chassis.
4. Located directly below the power modules is the fan tray which has thumb screws holding it into the chassis. Verify that the fan tray is secure. Cooling is accomplished by three fans in the tray, air baffles in the chassis door and fans in each of the power supply units. Air is forced into the chassis from the fan tray which cools the vertically mounted I/O cards and the integrated

circuits on the Backplane, as well as removing any heat generated by the power modules.



Warning! Do not open or remove the Front Door when the unit is powered. The door of each VX Router contains air baffles that are integral to the chassis' cooling system. The Backplane Integrated Circuits may overheat when operating with the front door open or removed.



Note: When mounting the chassis in a rack, insure that the fans' air flow is not restricted.

5. The temperature in the chassis is monitored in several locations. The power supplies have an internal temperature sensor that is monitored constantly for any conditions that may indicate a problem. Other temperature sensors are mounted in the fan trays, on the Controller card(s), on the I/O cards, and on the Backplane.



Note: If any of these sensors detect an over temperature condition, power will be removed from all sensitive components and the system will shut down.

6. As a further safeguard, all fan speeds are monitored and any fan speed that does not meet specification will cause the unit to set an alarm condition.



Note: All failure conditions send out notifications prior to shut down. For a detailed list of the alarm descriptions, see page 17.

7. When the VX Router has been inspected and found to be in good condition, the installation process can begin.

Order of Installation Events

Please refer to the **Quick Start Guides** included with your products for detailed instructions. VX Router Quick Start Guides are also available in **Appendix B, pages 46-51**.

How to Replace Modules

How to Install or Replace Input/Output Cards



Note: No shutdown is required prior to installing/replacing Input/Output Cards.

Step 1: Turn the two thumbscrews counterclockwise until they disengage from the chassis. Pull the card out using both handles.



Warning! Do not pull on the thumbscrews when removing the module – damage may occur!

OR: If a blank panel is present, remove the blank panel from the desired location using the thumbscrews.

Step 2: Place the new module upright so that the POWER LED is on the top. Grasp the module by the handles or by the outer edge of the aluminum housing. The card should slide freely until it reaches the backplane connector. At this point, use just enough force to firmly engage the card with the mating connector.



Warning! If the module does not slide into the connector, do not force it! Damage may occur. Remove the card and start over.

Step 3: Once the module is completely seated, hand-tighten the thumbscrews.



Warning! Do not tighten the thumbscrews with a screwdriver.

How to Install or Replace a Controller Card



Note: When using a single Controller, the left or upper Controller slot is always Primary.



Note: Replacing the Active Controller Card will interrupt service.

When replacing a Controller Card in a system with redundant controllers you may remove the Controller that is not active (Active LED is off) without interrupting service.

Step 1: Before removing a Primary Controller that is active you should cause a Fail-over to the Back-up Controller. This can be done by removing the LAN connection from the active Controller and waiting approximately 20-50 seconds for the Back-up Controller to take control, as indicated by the Active LED. After the Primary Controller is removed and replaced (following the steps 2-5), the Primary Controller will re-take control of the system and become the Active Controller.

Step 2: Turn the thumbscrews counterclockwise until they disengage from the chassis. Pull the Controller Card out using both black handles.

Step 3: Place the new module upright so that the ACTIVE LED is on the top. Grasp the module by the handles or by the outer edge of the aluminum housing. The card should slide freely until it reaches the backplane connector. At this point, use just enough force to firmly engage the card with the mating connector.



Warning! If the module does not slide easily into the connector, do not force it! Damage may occur. Remove the card and start over.

Step 4: Once the module is completely seated, hand-tighten the thumbscrews.



Warning! Do not tighten the thumbscrews with a screwdriver.

Step 5: Replace the RJ45 CAT5 LAN cable connection and/or the RS232 cable connection.

How to Replace a Fan Tray

Each of the VX Routers uses three DC fans to move air horizontally through the enclosure. Be sure not to block the air vents on the front or rear of the unit and leave at least 2" of space on both sides.



Note: Be sure to leave adequate ventilation space on both sides of the units (2" minimum), especially if the transmitters or receivers (e.g. Extenders) are being stacked above or below the VX Router.



Note: No shutdown is required prior to replacing the Fan Tray, but operating without fans for more than a few minutes is not recommended.

Step 1: Turn the four thumbscrews counterclockwise until they disengage from the chassis.

Step 2: Pull the Fan Tray module out using both black handles.

Step 3: Place the new module so that the aluminum housing is on the bottom. Hold the new Fan Tray by the handles and slide the aluminum housing into the card guides.



Warning! Do not operate the unit for an extended period without a Fan Tray installed.

Step 4: Hand-tighten the thumbscrews.



Warning! Do not tighten the thumbscrews with a screwdriver.

How to Replace a Power Supply



Warning! Disconnect the power cord before proceeding!



Note: No shutdown is required prior to replacing a Power Supply.

The Power Modules are universal input 120-240VAC, 50-60Hz. Use the proper power cord for your region (supplied with the unit). Although the VX Router functions properly with one power module, it is recommended that both modules be used, preferably connected to two independent power sources (for redundancy).

Step 1: Grasp the handle with one hand.

Step 2: Slide the green tab to the left with the other hand.

Step 3: Pull the Power Module out of the chassis.

Step 4: Insert the new Power Module into the chassis and slide it in until it reaches the backplane connector. The module should slide freely until it reaches the backplane connector. Use just enough force to firmly engage the card with the mating connector.



Warning! If the module does not slide easily into the connector, do not force it! Damage may occur. Remove the module and start over.

Part 2: Regulatory & Safety Requirements

Markings and labels on our products follow industry-standard conventions. Regulatory markings found on our products comply with domestic and many international requirements.

Regulatory Compliance

Thinklogical® products are designed and made in the U.S.A. Products have been tested by a nationally recognized testing laboratory and found to be compliant with the following standards (both domestic USA and many international locations).

North America

These products comply with the following standards:

Safety

ANSI/UL60950-1: 1st Edition (2003)

CAN/CSA C22.2 No. 60950-1-03

LASER Safety

CDRH 21CFR 1040.10

Class 1 LASER Product

Electromagnetic Interference

FCC CFR47, Part 15, Class A

Industry Canada ICES-003 Issue 2, Revision 1

Australia & New Zealand

This is a Class A product. In a domestic environment this product may cause radio interference, in which case the user may be required to take adequate measures.

European Union

Declaration of Conformity

Manufacturer's Name & Address: **Thinklogical®**
100 Washington Street
Milford, Connecticut 06460 USA
Telephone: 1-203-647-8700

Product Name

Models: VX40 Router, VX80 Router, VX160 Router, VX320 Router and VX320Video/Audio Router

These products comply with the requirements of the Low Voltage Directive 72/23/EEC and the EMC Directive 89/336/EEC.

Standards with Which Our Products Comply

Safety

CENELEC EN 60950-1, (2006)

LASER Safety

IEC60825:2001 Parts 1 and 2
Class 1 LASER Product

Electromagnetic Emissions

EN55022: 1994 (IEC/CSP1R22: 1993)
EN61000-3-2/A14: 2000
EN61000-3-3: 1994

Electromagnetic Immunity

EN55024: 1998 Information Technology Equipment-Immunity Characteristics
EN61000-4-2: 1995 Electro-Static Discharge Test
EN61000-4-3: 1996 Radiated Immunity Field Test
EN61000-4-4: 1995 Electrical Fast Transient Test
EN61000-4-5: 1995 Power Supply Surge Test
EN61000-4-6: 1996 Conducted Immunity Test
EN61000-4-8: 1993 Magnetic Field Test
EN61000-4-11: 1994 Voltage Dips & Interrupts Test

Supplementary Information

The following statements may be appropriate for certain geographical regions and might not apply to your location.

This Class A digital apparatus meets all requirements of the Canadian Interference-Causing Equipment Regulations.

Cet appareil numérique de la classe A respecte toutes les exigences du Règlement sur le matériel brouilleur du Canada.



Warning! This is a Class A product. In a domestic environment, this product may cause radio interference, in which case the user may be required to take adequate corrective measures.



Note: This equipment has been tested and found to comply with the limits for a Class A digital device, pursuant to part 15 of the FCC Rules. These limits are designed to provide reasonable protection against harmful interference when the equipment is operated in a commercial environment. This equipment generates, uses and can radiate radio frequency energy and, if not installed and used in accordance with the instruction manual, may cause harmful interference to radio communications in which case the user may be required to take adequate corrective measures at their own expense.



Note: This Class A digital apparatus complies with Canadian ICES-003 and has been verified as being compliant within the Class A limits of the FCC Radio Frequency Device Rules (FCC Title 47, Part 15, Subpart B CLASS 1), measured to CISPR 22: 1993 limits and methods of measurement of Radio Disturbance Characteristics of Information Technology Equipment.



Note: The user may notice degraded audio performance in the presence of electromagnetic fields.



Note: If using a keyboard that is noise susceptible, a ferrite ring on the keyboard cable may be needed to comply with Immunity Requirements

Product Serial Number

Thinklogical® products have a unique serial number printed on an adhesive label that is fixed, typically, to the underside of the unit. The serial number includes a date-code formatted as 2 digits for the week and 2 digits for the year, plus two to four digits for a unique unit number.

Example: Serial number **2813124** indicates that the unit was built in the **28th** week of the year **2013** and is unit number **124**.

Connection to the Product

Connections and installation hardware for our products use industry-standard devices and methods. All wiring connections to the customer equipment are designed to minimize proprietary or customized connectors and cabling. Power connections are made with regionally appropriate power cords and approved methods.

Part 3: Thinklogical® Support

Customer Support

Thinklogical® is an engineering company and you will receive any information you require directly from our most knowledgeable engineers. We believe that the first lines of support are design engineers that developed each particular product. Therefore, your questions will be handled promptly by our in-house engineers who are most familiar with your products.

Thank you for choosing Thinklogical® products for your application.

We appreciate your business and are dedicated to helping you successfully use our products.

thinklogical® is always here to help you.

To contact us, please use the following telephone numbers and internet-based methods:

Website

Check out our website for current product offerings, support information and general information about all of the products we offer.

Our internet website offers product information on all current systems, including technical specification sheets and installation guides (for viewing online or for download), product diagrams showing physical connections and other information you might need.

Internet: www.thinklogical.com



Note: Most online documents are stored as Adobe Acrobat “PDF” files. If you do not have the Adobe Acrobat reader needed to view PDF files, visit www.adobe.com for a download.

Email

Thinklogical® is staffed Monday through Friday from **8:30am to 5:00pm**, Eastern Time Zone. We will do our best to respond to your email inquiries promptly. Please use one of the following email addresses:

info@thinklogical.com – Information on Thinklogical® and our products.

sales@thinklogical.com – Sales Department - orders, questions or issues.

support@thinklogical.com – Product support, technical issues or questions, product repairs and request for Return Authorization.

Telephone

Telephone Sales: Contact our expert, technically oriented sales staff in Milford, CT at **1-203-647-8700** or if in the continental US, you may use our **toll-free number 1-800-291-3211**. We are here Monday through Friday from 8:30am to 5:00pm, Eastern Time Zone. Ask for their direct dial phone number when you call.

Telephone Product Support: Contact Product Support in Milford, Connecticut at **1-203-647-8700**. The support lines are manned Monday through Friday, 8:30am to 5:00pm, Eastern Time Zone.

International Sales: Please contact our US sales staff in Milford, CT at **1-203-647-8700**. We are here Monday through Friday, 8:30am to 5:00pm, Eastern Time Zone (same as New York City). If leaving a voice message, please provide a preferred time to call back so we may reach you at your convenience.

Our switchboard attendant will direct your call during regular business hours. We have an automated attendant answering our main telephone switchboard after regular business hours and holidays. You can

leave a voice message for an individual at any time. Our sales representatives have direct numbers to facilitate each call.

Fax

Our company facsimile number is **1-203-783-9949**. Please indicate the nature of the fax on your cover sheet and provide return contact information.

Product Support

Thinklogical's® support personnel are available Monday through Friday from 8:30am to 5:00pm, Eastern Time Zone. If your application might require assistance at some time outside of our normal business hours, please contact us beforehand and we will do our best to make arrangements to help you with your Thinklogical® products.

Warranty

Thinklogical® warrants this product against defects in materials and workmanship for a period of one year from the date of delivery. Thinklogical® and its suppliers disclaim any and all other warranties.



Note: *Thinklogical®* Inc. products carry a one year warranty, with longer term available at time of purchase on most products. Please refer to your product invoice for your products Warranty Terms & Conditions.

Defect remedy shall be, repair or replacement of the product, provided that the defective product is returned to the authorized dealer within a year from the date of delivery.

If you wish to return your device, contact the *Thinklogical®* authorized dealer where you purchased the device, or if you purchased directly, call Thinklogical at 1-800-291-3211 (USA).

Return Authorization

If you have any issue with any Thinklogical product, have product questions or need technical assistance with your Thinklogical system, please contact **Customer Support** at **1-800-291-3211 (USA only)** or **1-203-647-8700** and let us help.

If you must return a product to *Thinklogical®* directly, Customer Support will ask you to describe the problem and will issue you a **Return Merchandise Authorization** number (RMA#).

Pack the device in its original box, if possible, and return it with the RMA# on the box.



Note: Do not return a product to Thinklogical® without a *Return Material Authorization Number*.

Return address for products with Return Material Authorization:

Thinklogical, LLC®
Attn: RMA#
100 Washington Street
Milford, CT 06460 USA
PH: 800-291-3211 (USA only)

Appendix A: Ordering Information

VX40 and VX80 Routers

Thinklogical's VX40 Router Ordering Information

Part Number	Description
Velocity Matrix Router 40	
VXR-000040	Velocity Matrix Router 40 Chassis
VXR-000040 REV B	Velocity Matrix Router 40 Chassis, Common Criteria EAL 4 Certified
Velocity Matrix Router 40 Data Cards	
VXM-DI0005	Velocity Matrix Router 40 Data Upstream Card, 5 Ports, SFP+, Multi-mode
VXM-DI0005 REV A	Velocity Matrix Router 40 Data Upstream Card, 5 Ports, SFP+, Multi-mode, Common Criteria EAL 4 Certified
VXM-DO0005	Velocity Matrix Router 40 Data Downstream Card, 5 Ports, SFP+, Multi-mode
VXM-DO0005 REV A	Velocity Matrix Router 40 Data Downstream Card, 5 Ports, SFP+, Multi-mode, Common Criteria EAL 4 Certified
VXM-DI0S05	Velocity Matrix Router 40 Data Upstream Card, 5 Ports, SFP+, Single-mode
VXM-DO0S05	Velocity Matrix Router 40 Data Downstream Card, 5 Ports, SFP+, Single-mode
VXM-DI0E05	Velocity Matrix Router 40 Vacant Data Input Card, 5 Ports, No SFP+
VXM-DO0E05	Velocity Matrix Router 40 Vacant Data Output Card, 5 Ports, No SFP+
Velocity Matrix Router 40 Spares	
VXM-000005	Velocity Matrix Router 40/80 Controller Card
VXM-000006	Velocity Matrix Router 40 Fan Tray
VXM-000007	Velocity Matrix Router 40/80 Power Supply
VXM-000271	Velocity Matrix Router 40 Backplane

Thinklogical's VX80 Router Ordering Information

Part Number	Description
VXR-000080	Velocity Matrix Router 80 Chassis
VXM-000005	Velocity Matrix Router 40/80 Controller Card
VXM-00RSD5	Velocity Matrix Router 40/80 Controller Card with removable SD card
VXM-000007	Velocity Matrix Router 40/80 Power Supply
VXM-000019	Velocity Matrix Router 80 Fan Tray
VXM-000029	Velocity Matrix Router 80 Backplane
VXM-D00005	Velocity Matrix Router 80 Data Input/Output Card, 5 ports, SFP+, Multi-mode
VXM-D00C05	Velocity Matrix Router 80 Data Input/Output Card, 5 Ports, Coaxial
VXM-D00E05	Velocity Matrix Router 80 Data Input/Output Card, 5 Ports, No SFP+
VXM-D00S05	Velocity Matrix Router 80 Data Input/Output Card, 5 Ports, SFP+, Single-mode

VX160 Routers

Thinklogical's VX160 Router Ordering Information

Part Number	Description
Velocity Matrix Router 160	
VXR-000160	Velocity Matrix Router 160 Chassis
VXR-000160 REV B	Velocity Matrix Router 160 Chassis, Common Criteria EAL 4 Certified
Velocity Matrix Router 160 Data Cards	
VXM-DI0020	Velocity Matrix Router 160 Data Upstream Card, 20 Ports, SFP+, Multi-mode
VXM-DI0020 REV B	Velocity Matrix Router 160 Data Upstream Card, 20 Ports, SFP+, Multi-mode, Common Criteria EAL 4 Certified
VXM-DO0020	Velocity Matrix Router 160 Data Downstream Card, 20 Ports, SFP+, Multi-mode
VXM-DO0020 REV B	Velocity Matrix Router 160 Data Downstream Card, 20 Ports, SFP+, Multi-mode, Common Criteria EAL 4 Certified
VXM-DI0S20	Velocity Matrix Router 160 Data Upstream Card, 20 Ports, SFP+, Single-mode
VXM-DO0S20	Velocity Matrix Router 160 Data Downstream Card, 20 Ports, SFP+, Single-mode
VXM-DI0E20	Velocity Matrix Router 160 Vacant Data Input Card, 20 Ports, No SFP+
VXM-DO0E20	Velocity Matrix Router 160 Vacant Data Output Card, 20 Ports, No SFP+
VXM-DI0R20	Velocity Matrix Router 160 Data Input Repeater Card, 20 Ports, SFP+, Multi-mode
Velocity Matrix Router 160 Spares	
VXM-000001	Velocity Matrix Router 160 Controller Card
VXM-000002	Velocity Matrix Router 160 Fan Tray
VXM-000003	Velocity Matrix Router 160 Power Supply

VX320, VX320Video and VX320Audio Routers

Thinklogical's VX320 Router Ordering Information

Part Number	Description
Velocity Matrix Router 320	
VXR-000320	Velocity Matrix Router 320 Chassis
VXR-000320 REV A	Velocity Matrix Router 320 Chassis, Common Criteria EAL 4 Certified
Velocity Matrix Router 320 Data Cards	
VXM-D00016	Velocity Matrix Router 320 Data Upstream/Downstream Card, 16 Ports, SFP+, Multi-mode
VXM-D00016 REV A	Velocity Matrix Router 320 Data Upstream/Downstream Card, 16 Ports, SFP+, Multi-mode, Common Criteria EAL 4 Certified
VXM-D00S16	Velocity Matrix Router 320 Data Upstream/Downstream Card, 16 Ports, SFP+, Single-mode
VXM-D00E16	Velocity Matrix Router 320 Vacant Data Upstream/Downstream Card, 16 Ports, No SFP+
VXM-D00R16	Velocity Matrix Router 320 Data In/Out Repeater Card, 16 Ports, SFP+, Multi-mode
VXM-D00T16	Velocity Matrix Router 320 Data In/Out Re-timer Card, 16 Ports, SFP+, Multi-mode
Velocity Matrix Router 320 Spares	
VXM-000008	Velocity Matrix Router 320 Controller Card
VXM-000031	Velocity Matrix Router 320 Controller Card with OSD
VXM-000009	Velocity Matrix Router 320 Fan Tray
VXM-000010	Velocity Matrix Router 320 Power Supply

Thinklogical's VX320VIDEO Router Ordering Information

Part Number	Description
Velocity Matrix Router 320Video	
VXR-V00320	Velocity Matrix Router 320 VIDEO Chassis
Velocity Matrix Router 320Video Data Cards	
VXM-D00016	Velocity Matrix Router 320V Data Upstream/Downstream Card, 16 Ports, SFP+, Multi-mode
VXM-D00S16	Velocity Matrix Router 320V Data Upstream/Downstream Card, 16 Ports, SFP+, Single-mode
VXM-D00E16	Velocity Matrix Router 320V Vacant Data Upstream/Downstream Card, 16 Ports, No SFP+
VXM-D00R16	Velocity Matrix Router 320V Data In/Out Repeater Card, 16 Ports, SFP+, Multi-mode
VXM-D00T16	Velocity Matrix Router 320V Data In/Out Re-timer Card, 16 Ports, SFP+, Multi-mode
Velocity Matrix Router 320Video Spares	
VXM-000018	Velocity Matrix Router 320 VIDEO/AUDIO Controller Card
VXM-000032	Velocity Matrix Router 320 VIDEO/AUDIO Controller Card with OSD
VXM-000009	Velocity Matrix Router 320 Fan Tray
VXM-000010	Velocity Matrix Router 320 Power Supply

Thinklogical's VX320AUDIO Router Ordering Information

Part Number	Description
Velocity Matrix Router 320Audio	
VXR-A00320	Velocity Matrix Router 320 AUDIO Chassis
Velocity Matrix Router 320Audio Data Cards	
VXM-A00016	Velocity Matrix Router 320A Data Upstream/Downstream Card, 16 Ports, SFP+, Multi-mode
VXM-A00S16	Velocity Matrix Router 320A Data Upstream/Downstream Card, 16 Ports, SFP+, Single-mode
VXM-A00E16	Velocity Matrix Router 320A Vacant Data Upstream/Downstream Card, 16 Ports, No SFP+
VXM-A00R16	Velocity Matrix Router 320A Data In/Out Repeater Card, 16 Ports, SFP+, Multi-mode
VXM-A00T16	Velocity Matrix Router 320A Data In/Out Re-timer Card, 16 Ports, SFP+, Multi-mode
Velocity Matrix Router 320Video/Audio Spares	
VXM-000018	Velocity Matrix Router 320 VIDEO/AUDIO Controller Card
VXM-000032	Velocity Matrix Router 320 VIDEO/AUDIO Controller Card with OSD
VXM-000009	Velocity Matrix Router 320 Fan Tray
VXM-000010	Velocity Matrix Router 320 Power Supply

QUICK-START GUIDE

As used with Thinklogical's Q-4300 and Velocitydvi-3AV+ Fiber-Optic Extension Systems

with VQM-3AV+ (Audio/Video) and VQM-3AVV+ (Audio/Dual Video) Transmitter & Receiver Modules

router VX80

KVM Matrix Switch
Powered by
MRTS Technology

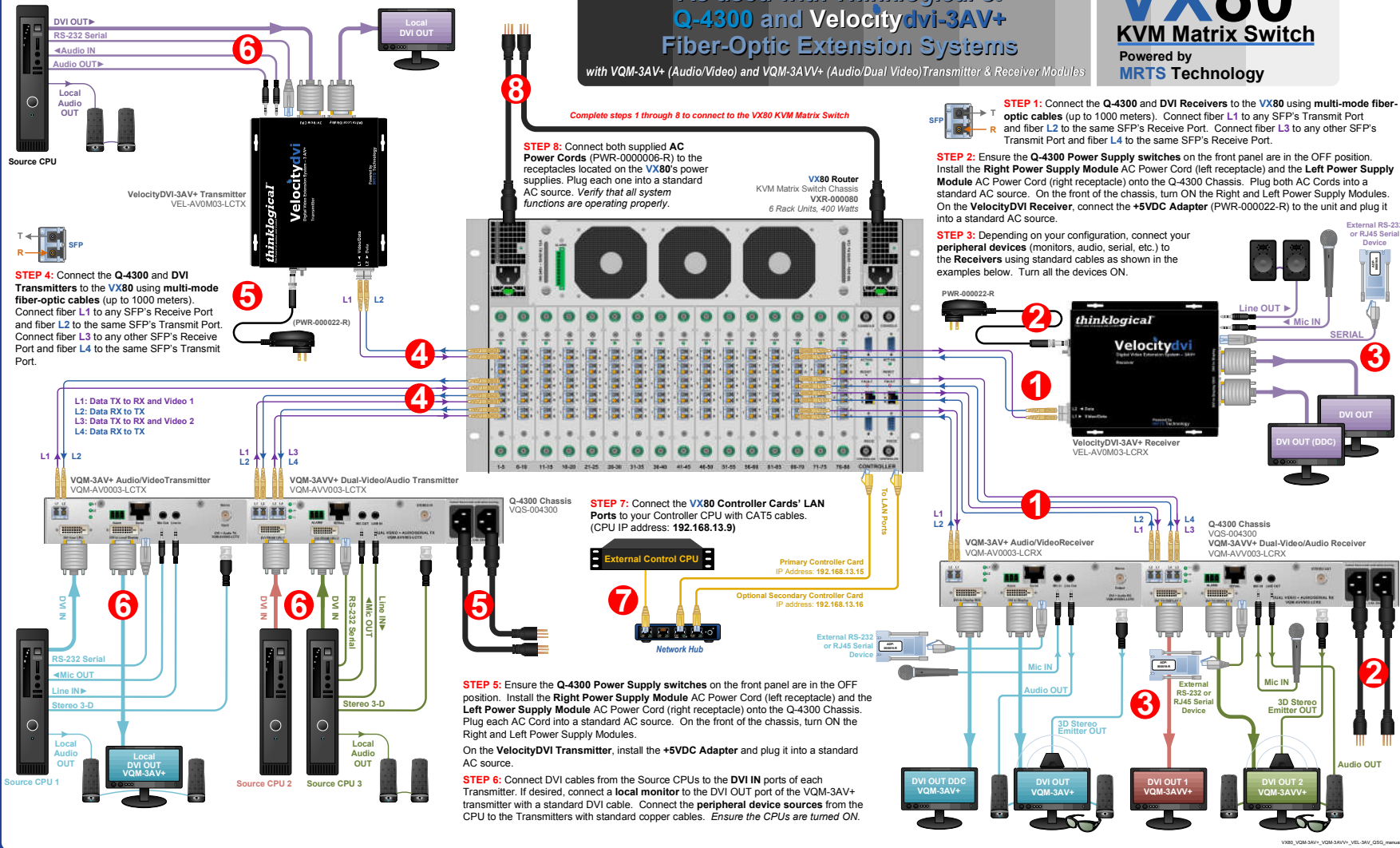

Complete steps 1 through 8 to connect to the VX80 KVM Matrix Switch

STEP 8: Connect both supplied AC Power Cords (PWR-000006-R) to the receptacles located on the VX80's power supplies. Plug each one into a standard AC source. Verify that all system functions are operating properly.

STEP 1: Connect the Q-4300 and DVI Receivers to the VX80 using multi-mode fiber-optic cables (up to 1000 meters). Connect fiber L1 to any SFP's Transmit Port and fiber L2 to the same SFP's Receive Port. Connect fiber L3 to any other SFP's Transmit Port and fiber L4 to the same SFP's Receive Port.

STEP 2: Ensure the Q-4300 Power Supply switches on the front panel are in the OFF position. Install the Right Power Supply Module AC Power Cord (left receptacle) and the Left Power Supply Module AC Power Cord (right receptacle) onto the Q-4300 Chassis. Plug both AC Cords into a standard AC source. On the front of the chassis, turn ON the Right and Left Power Supply Modules. On the VelocityDVI Receiver, connect the +5VDC Adapter (PWR-00022-R) to the unit and plug it into a standard AC source.

STEP 3: Depending on your configuration, connect your peripheral devices (monitors, audio, serial, etc.) to the Receivers using standard cables as shown in the examples below. Turn all the devices ON.

STEP 4: Connect the Q-4300 and DVI Transmitters to the VX80 using multi-mode fiber-optic cables (up to 1000 meters). Connect fiber L1 to any SFP's Transmit Port and fiber L2 to the same SFP's Receive Port. Connect fiber L3 to any other SFP's Receive Port and fiber L4 to the same SFP's Transmit Port.

L1: Data TX to RX and Video 1
L2: Data RX to TX
L3: Data TX to RX and Video 2
L4: Data RX to TX

STEP 7: Connect the VX80 Controller Cards' LAN Ports to your Controller CPU with CAT5 cables. (CPU IP address: 192.168.13.9)

STEP 5: Ensure the Q-4300 Power Supply switches on the front panel are in the OFF position. Install the Right Power Supply Module AC Power Cord (left receptacle) and the Left Power Supply Module AC Power Cord (right receptacle) onto the Q-4300 Chassis. Plug each AC Cord into a standard AC source. On the front of the chassis, turn ON the Right and Left Power Supply Modules. On the VelocityDVI Transmitter, install the +5VDC Adapter and plug it into a standard AC source.

STEP 6: Connect DVI cables from the Source CPUs to the DVI IN ports of each Transmitter. If desired, connect a local monitor to the DVI OUT port of the VQM-3AV+ transmitter with a standard DVI cable. Connect the peripheral device sources from the CPU to the Transmitters with standard copper cables. Ensure the CPUs are turned ON.

thinklogical®

QUICK-START GUIDE

As used with *Thinklogical's* Velocitydvi-3AV+, Velocitykvm Desktop, and Q-Series Fiber-Optic Extension Systems

STEP 4: Connect your Velocity Q-Series Transmitters to the VX160 using multi-mode fiber-optic cables (up to 1000 meters). Connect fiber L1 to any Upstream SFP's Receive Port and fiber L2 to the same SFP's Transmit Port. Connect fiber L3 to any Upstream SFP's Receive Port and fiber L4 to the same SFP's Transmit Port. Connect fiber K1 to any Upstream SFP's Receive Port and fiber K2 to the same SFP's Transmit Port.

STEP 5: On the front of the Q-4300 Chassis, ensure the ON/OFF switch is in the OFF position. Install the Right Power Supply Module AC Power Cord (left receptacle) and the Left Power Supply Module AC Power Cord (right receptacle) onto each chassis. Plug each AC Cord into a standard AC source. Turn ON the Right and Left Power Supply Modules for each chassis.

STEP 6: Connect DVI cables from the source CPUs to each DVI Transmitter's DVI IN 1 and DVI IN 2 ports. Connect the peripheral device sources from the source CPUs to each Transmitter with standard copper cables. Ensure the CPUs are turned ON.

STEP 7: Connect the Controller Cards' LAN Ports to your Control CPU with CAT5 cables. (CPU IP address: 192.168.13.9)

- L1: Data Tx to Rx & Video 1
- L2: Data Rx to Tx
- L3: Data Tx to Rx & Video 2
- L4: Data Rx to Tx
- K1: Data Tx to Rx
- K2: Data Rx to Tx

Dual DVI & HID/Audio Sources

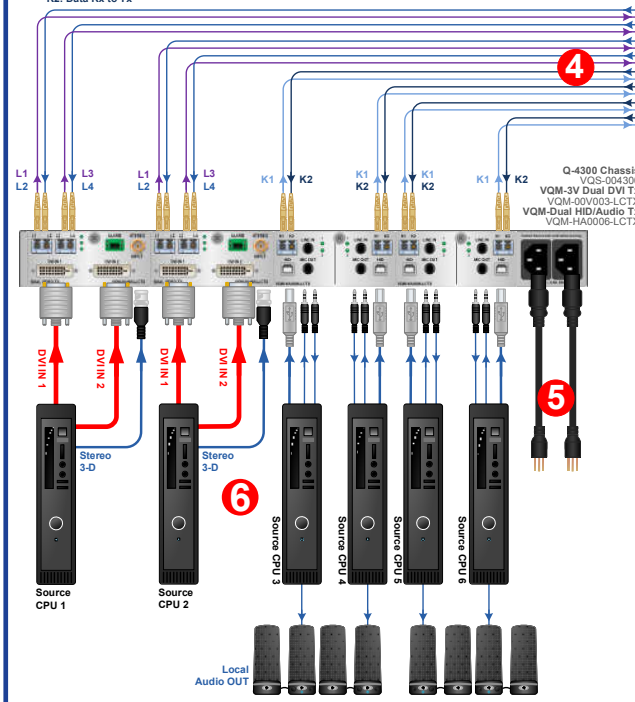

VX160 Router KVM Matrix Switch Chassis
 VXR-000160
 16 Rack Units, 850 Watts
 Upstream Data Cards
 VXM-DI0020
 Downstream Data Cards
 VXM-DO0020
 Controller Cards
 VXM-000001

STEP 8: Connect both supplied AC Power Cords (PWR-0000056-R) to the receptacles located on the VX160's power supplies. Plug each one into a standard AC source.

Verify that all system functions are operating properly.

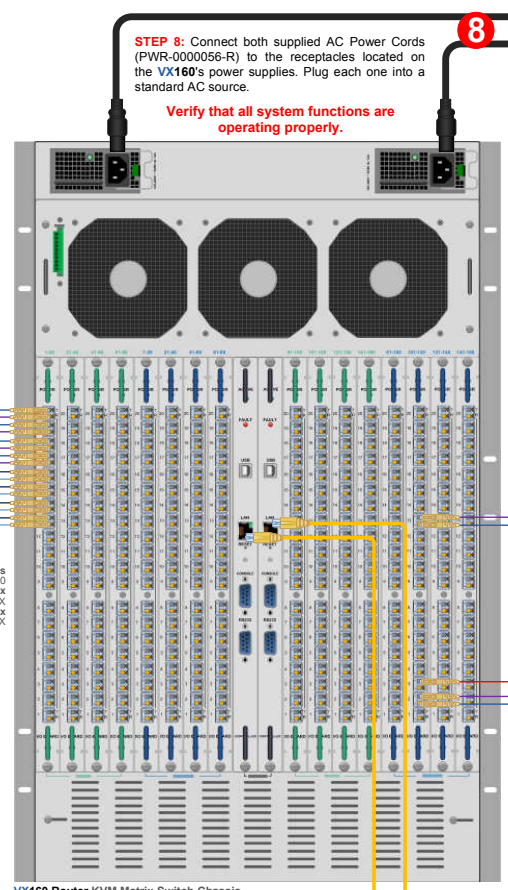

router VX160 KVM Matrix Switch

Powered by MRTS Technology

Complete steps 1 through 8 to connect to the VX160 KVM Matrix Switch:

STEP 1: Connect your VelocityDVI and VDM Receivers to the VX160 using multi-mode fiber-optic cables (up to 1000 meters). Connect fiber L1 to any Downstream SFP's Transmit Port and L2 to the same SFP's Receive Port. Connect fiber L3 to any other Downstream SFP's Transmit Port.

STEP 2: Install the VelocityDVI Receiver's +5VDC Power Supply and plug it into a standard AC source. Ensure the VDM Receiver's power switch is in the OFF position. Install the AC Power Cord and plug it into a standard AC source. Turn the power switch ON.

STEP 3: Connect your display devices to each Receiver's DVI to Display ports with standard DVI cables. Connect the peripheral devices with standard copper cables. Ensure the devices are turned ON.

Single Head DVI/Audio/Serial Destination

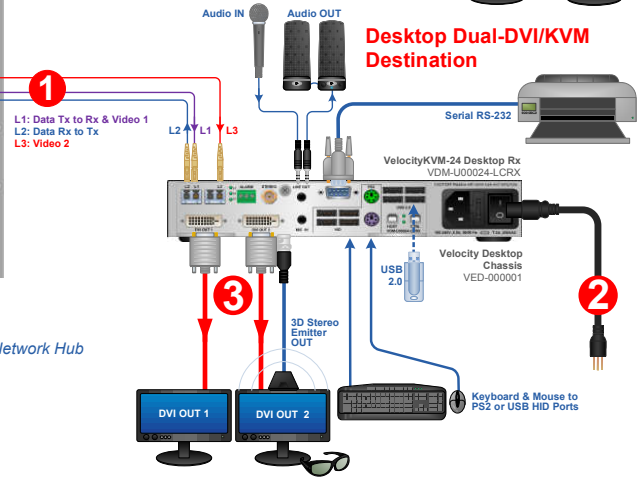

VX160_VOM-3V_VOM-HA6-LCTX_to_VEL-3AV_VDM-24-LCRX_GSG_manual

QUICK-START GUIDE

As used with *Thinklogical's* Velocityrgb/dvi-10 and Velocitydvi-3 Fiber Extension Systems

VXVIDEO 320router

KVM Matrix Switch
Powered by MRTS Technology

Complete steps 1 through 8 to connect to your Thinklogical VX320VIDEO Router KVM Matrix Switch

Thinklogical's **VXVIDEO 320 Router** features redundant Power Supplies and Fail-Over Controller Modules for uninterrupted performance, even during system reconfiguration, updates or debug. The **VXVIDEO 320 Router** remains fully functional with only one Power Supply installed or with one Controller activated.

NOTE: When using a single Controller, the upper module must be used.

Single-Head DVI Source

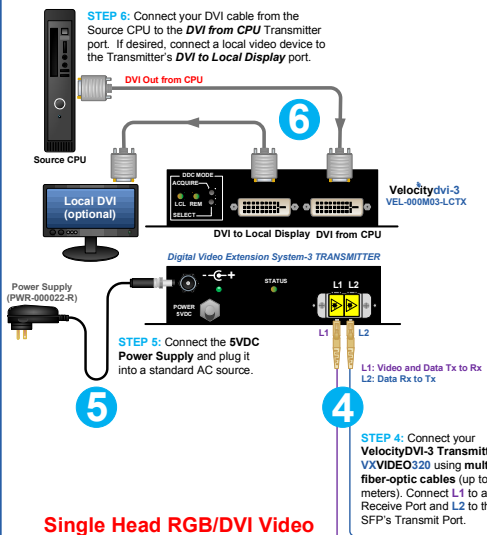

Single Head RGB/DVI Video & Audio Source

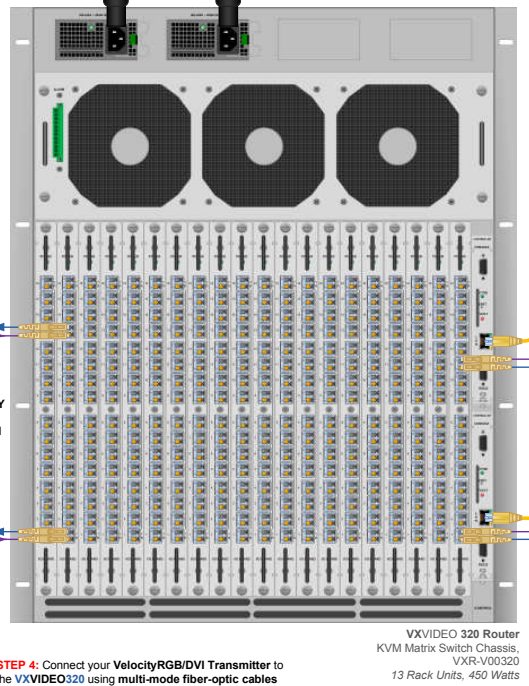
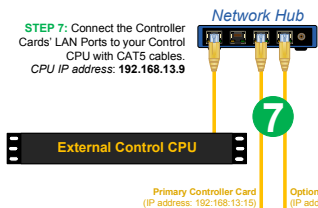
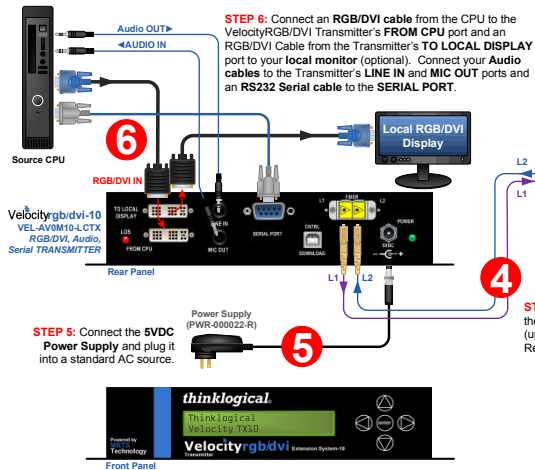

Single-Head DVI Destination

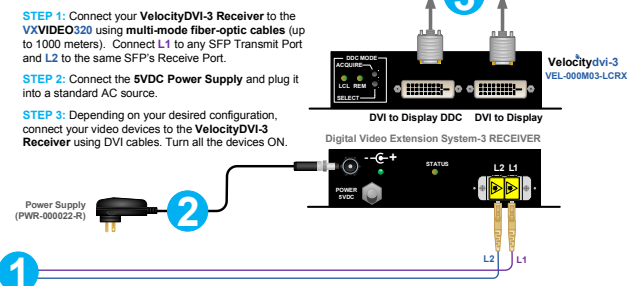

Single Head RGB/DVI Video & Audio Destinations

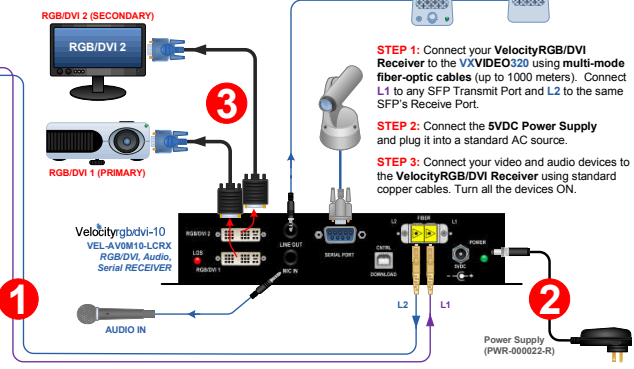

thinklogical®

VX320VIDEO3_VEL-3_VEL-10_QSG_manual

VX AUDIO 320 Router

KVM Matrix Switch

QUICK-START GUIDE

As used with the Velocity dvi-3AV+ and the Velocity kvm-2AWA (Separate Audio Paths) Fiber Extension Systems

As used with Thinklogical's® Velocity kvm-4W Rx with Separate Audio Path & Velocity dvi-3AV+ Tx with Separate Audio Path Video Extension Systems

Powered by MRTS Technology

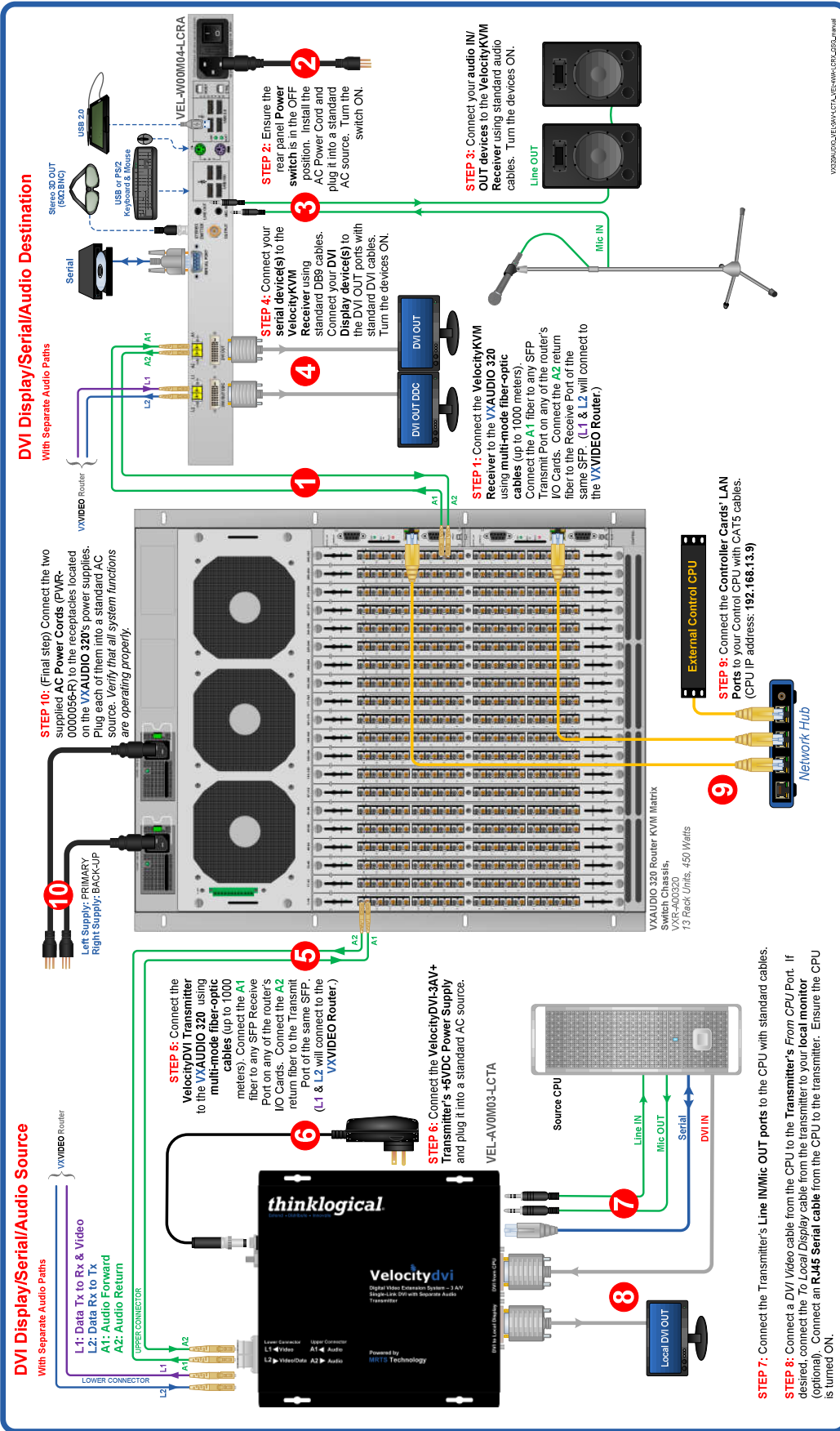

VX320Audio Router Quick Start Guide

router router VX40/VX80 KVM Matrix Switch SD Flash Drive Replacement Procedure

PHONE: 1-800-291-3211
WEBSITE: www.thinklogical.com
EMAIL: support@thinklogical.com

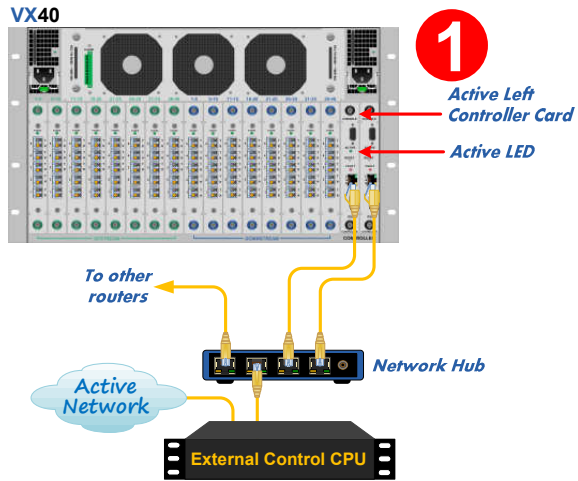

STEP 1: To replace the SD Flash Drive on a **VX40** or **VX80** Controller Card it is not necessary to power down the router if both Controller Cards are installed and connected to an active network.

STEP 2: When removing the Primary (left) Controller Card, first remove the network CAT5 cable from the left card's LAN Port. The Active LED will extinguish on the left card and illuminate on the right card. The left card can now be removed to replace the SD Flash Drive. (Proceed to STEPS 3-4.) Reinstall the Primary Card and reconnect to the network.

Before removing the Secondary (right) Controller Card, reinstall the Primary Card and reconnect it to the network. Wait for the Primary Active LED to illuminate. Remove the secondary CAT5 cable. The active LED will remain with the Primary Controller Card. The right card can now be removed. (Proceed to STEPS 3-4.) Reinstall the Secondary Card and reconnect to the network.

If there is **only one Controller Card (left)** installed, the unit will power down when the Controller Card is removed. (Proceed to STEPS 3-4.) Reinstall the Primary Card and reconnect to the network.

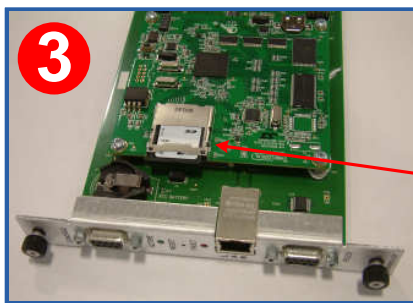
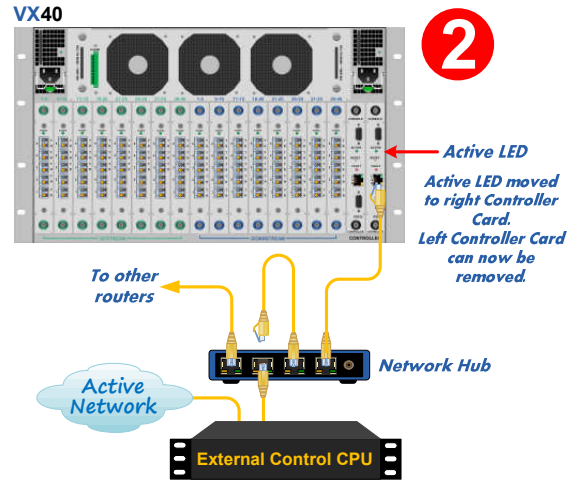

STEP 3: Remove the Controller Card that will have the SD Flash Drive replaced. The SD Flash Drive is the small Secure Digital Memory Drive at J1 on the AVR Processor Board (PCB-000170-R).

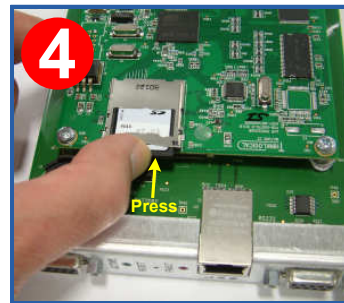

STEP 4: To eject the SD Flash Drive from its connector bracket at J1, press the exposed edge of the card into the bracket. A spring-latch will release and eject the SD Flash Drive. The new SD Flash Drive can now be inserted into the J1 connector bracket until it snaps into place.

STEP 5: When both updated Controller Cards have been reinstalled into the router Chassis and connected to the network, verify that the Active LED is illuminated on the Primary Controller and that all system functions are operating properly. **If reinstalling a single Controller Card, it must go into the Primary (left) slot.**

VX40_VX80_SD_Flash_Drive_Replacement_Guide

Copyright © 2013. All rights reserved. Printed in the U.S.A. All trademarks and service marks are the property of their respective owners.

VX160 SD Flash Card Replacement

router VX160 KVM Matrix Switch SD Flash Drive Replacement Procedure

PHONE: 1-800-291-3211
 WEBSITE: www.thinklogical.com
 EMAIL: support@thinklogical.com

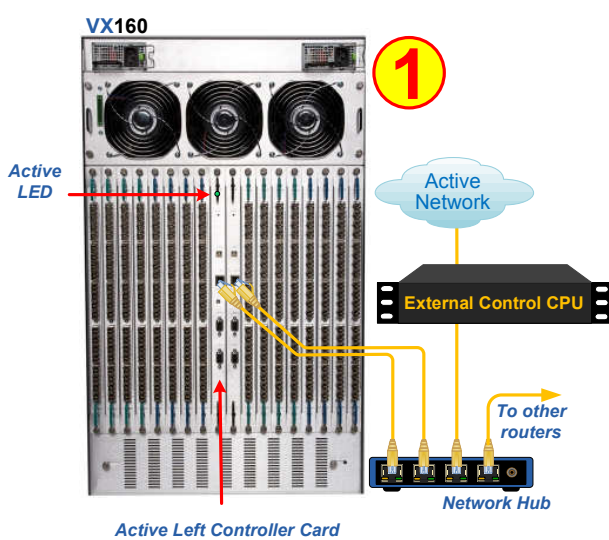

STEP 1: To replace the SD Flash Drive on a VX160 Controller Card it is not necessary to power down the VX160 if both Controller Cards are installed and connected to an active network.

STEP 2: When removing the Primary (left) Controller Card, first remove the network CAT5 cable from the left card's LAN Port. The Active LED will extinguish on the left card and illuminate on the right card (20-50 seconds). The left card can now be removed to replace the SD Flash Drive. (Proceed to STEPS 3-4.) Reinstall the Primary Card and reconnect to the network.

Before removing the Secondary (right) Controller Card, reinstall the Primary Card and reconnect it to the network. Wait for the Primary Active LED to illuminate. Remove the secondary CAT5 cable. The active LED will remain with the Primary Controller Card. The right card can now be removed. (Proceed to STEPS 3-4.) Reinstall the Secondary Card and reconnect to the network.

If there is only one Controller Card (left) installed, the unit will power down when the Controller Card is removed. (Proceed to STEPS 3-4.) Reinstall the Primary Card and reconnect to the network.

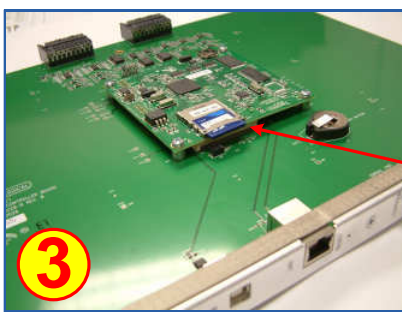
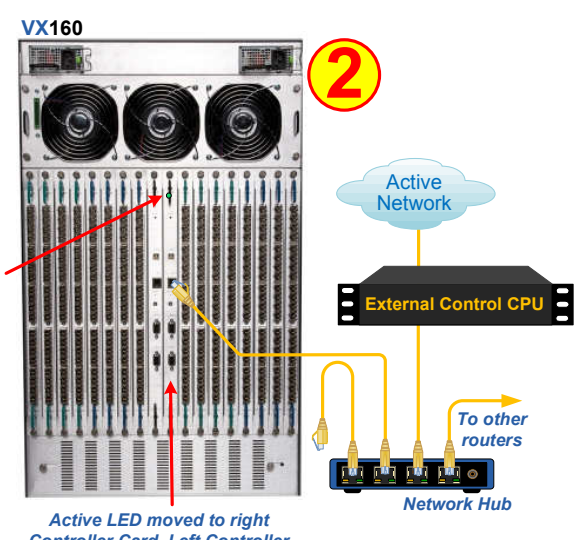

STEP 3: Remove the Controller Card that will have the SD Flash Drive replaced. The SD Flash Drive is the small Secure Digital Memory Drive at J1 on the AVR Processor Board (PCB-000170-R).

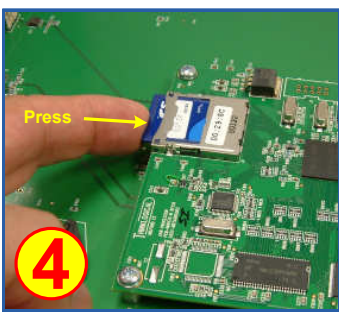

STEP 4: To eject the SD Flash Drive from its connector bracket at J1, press the exposed edge of the card into the bracket. A spring-latch will release and eject the SD Flash Drive. The new SD Flash Drive can now be inserted into the J1 connector bracket until it snaps into place.

5 **STEP 5:** When both updated Controller Cards have been reinstalled into the VX160 Chassis and connected to the network, verify that the Active LED is illuminated on the Primary Controller and that all system functions are operating properly. If reinstalling a single Controller Card, it must go into the Primary (left) slot.

VX160_SD_Flash_Drive_Replacement_Guide_Rev_A

Copyright © 2010. All rights reserved. Printed in the U.S.A. All trademarks and service marks are the property of their respective owners.

router VX320

KVM Matrix Switch *SD Flash Drive Replacement Procedure*

PHONE: 1-800-291-3211
 WEBSITE: www.thinklogical.com
 EMAIL: support@thinklogical.com

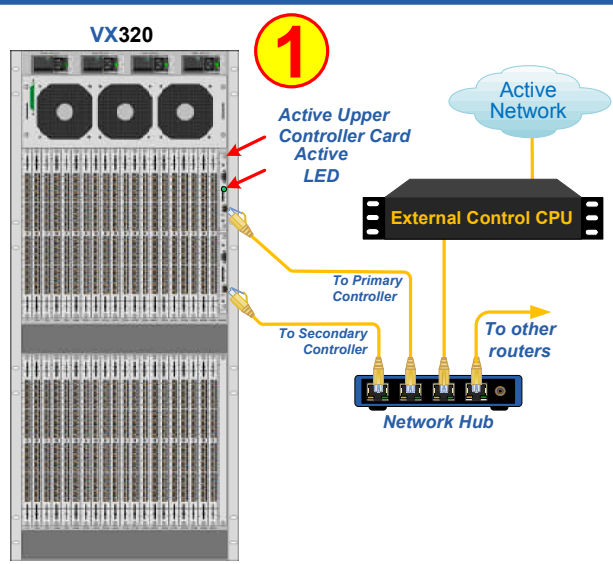

STEP 1: To replace the SD Flash Drive on a VX320 Controller Card it is *not* necessary to power down the VX320 if both Controller Cards are installed and connected to an active network.

STEP 2: When removing the Primary (upper) Controller Card, first remove the network CAT5 cable from the upper card's LAN Port. The Active LED will extinguish on the upper card and illuminate on the lower card (20-50 seconds). The upper card can now be removed to replace the SD Flash Drive. (Proceed to STEPS 3-4.) Reinstall the Primary Card and reconnect to the network.

Before removing the Secondary (lower) Controller Card, reinstall the Primary Card and reconnect it to the network. Wait for the Primary Active LED to illuminate. Remove the secondary CAT5 cable. The active LED will remain with the Primary Controller Card. The lower card can now be removed. (Proceed to STEPS 3-4.) Reinstall the Secondary Card and reconnect to the network.

If there is **only one Controller Card (upper) installed,** the unit will power down when the Controller Card is removed. (Proceed to STEPS 3-4.) Reinstall the Primary Card and reconnect to the network.

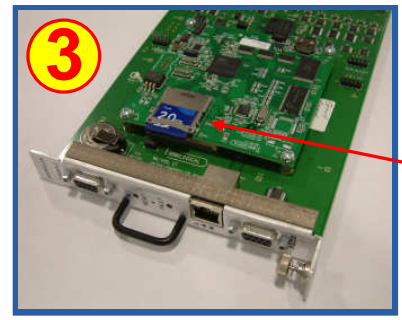
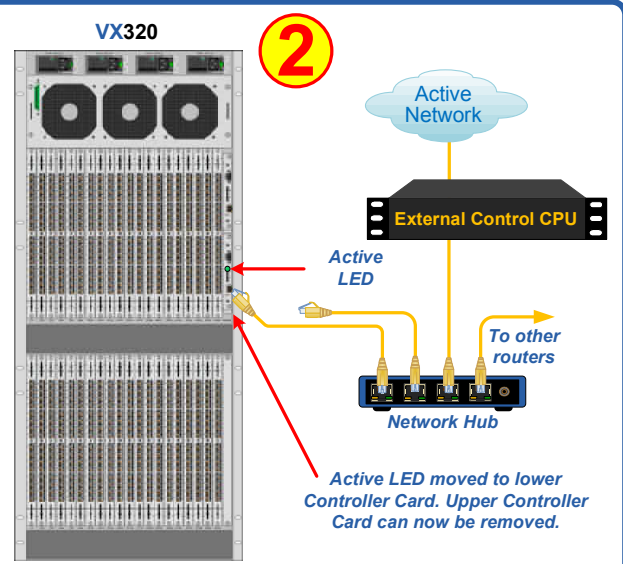

STEP 3: Remove the Controller Card that will have the SD Flash Drive replaced. The SD Flash Drive is the small Secure Digital Memory Drive at J1 on the AVR Processor Board (PCB-000170-R).



STEP 4: To eject the SD Flash Drive from its connector bracket at J1, press the exposed edge of the card into the bracket. A spring-latch will release and eject the SD Flash Drive. The new SD Flash Drive can now be inserted into the J1 connector bracket until it snaps into place.

5 **STEP 5:** When both updated Controller Cards have been reinstalled into the VX320 Chassis and connected to the network, verify that the Active LED is illuminated on the Primary Controller and that all system functions are operating properly. **If reinstalling a single Controller Card, it must go into the Primary (upper) slot.**

Copyright © 2010. All rights reserved. Printed in the U.S.A. All trademarks and service marks are the property of their respective owners.

PHONE: 1-800-291-3211
 WEBSITE: www.thinklogical.com
 EMAIL: support@thinklogical.com

SD Flash Drive Replacement Procedure



thinklogical
 Extend • Distribute • Innovate

2

VXVIDEO 320

STEP 1: To replace the SD Flash Drive on a VXVIDEO 320 Controller Card it is not necessary to power down the VXVIDEO 320 if both Controller Cards are installed and connected to an active network.

STEP 2: When removing the Primary (upper) Controller Card, first remove the network CAT5 cable from the upper card's LAN Port. The Active LED will extinguish on the upper card and illuminate on the lower card (20-50 seconds). The upper card can now be removed to replace the SD Flash Drive. (Proceed to STEPS 3-4.) Reinstall the Primary Card and reconnect to the network.

Before removing the Secondary (lower) Controller Card, reinstall the Primary Card and reconnect it to the network. Wait for the Primary Active LED to illuminate. Remove the secondary CAT5 cable. The active LED will remain with the Primary Controller Card. The lower card can now be removed. (Proceed to STEPS 3-4.) Reinstall the Secondary Card and reconnect to the network.

If there is only one Controller Card (upper) installed, the unit will power down when the Controller Card is removed. (Proceed to STEPS 3-4.) Reinstall the Primary Card and reconnect to the network.

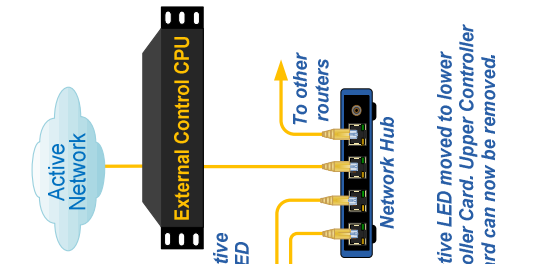

1

VXVIDEO 320

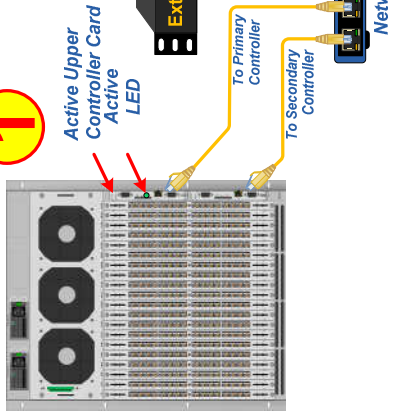

STEP 3: Remove the Controller Card that will have the SD Flash Drive replaced. The SD Flash Drive is the small Secure Digital Memory Drive at J1 on the AVR Processor Board (PCB-000170-R).



3



SD Flash Drive



4

STEP 4: To eject the SD Flash Drive from its connector bracket at J1, press the exposed edge of the card into the bracket. A spring-latch will release and eject the SD Flash Drive. The new SD Flash Drive can now be inserted into the J1 connector bracket until it snaps into place.

5

STEP 5: When both updated Controller Cards have been reinstalled into the VXVIDEO 320 Chassis and connected to the network, verify that the Active LED is illuminated on the Primary Controller and that all system functions are operating properly. **If reinstalling a single Controller Card, it must go into the Primary (upper) slot.**

Active LED moved to lower Controller Card. Upper Controller Card can now be removed.

VXVIDEO_320_SD_Flash_Drive_Replacement_Guide_Rev_A
 Copyright © 2010. All rights reserved. Printed in the U.S.A. All trademarks and service marks are the property of their respective owners.

Appendix D: Secure Applications

VX Router Control

When used in a secure application, the VX Router and External Computer (server) used to manage the Router must be located in a physically secure environment to which only trusted administrators have access. Similarly, the server used to manage the VX Router must be physically protected and have suitable identification/authentication mechanisms to ensure that only trusted administrators have access.

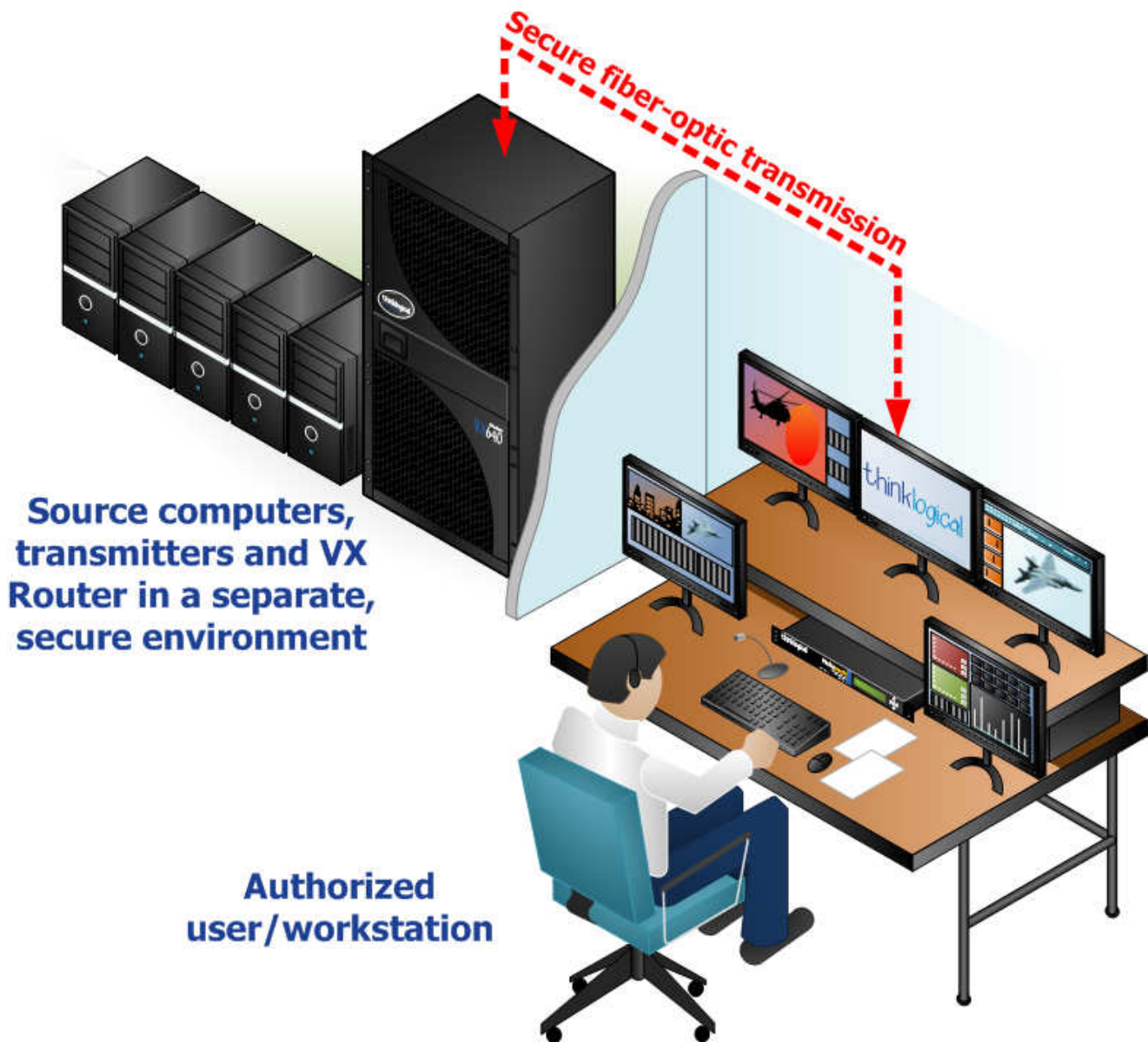

Thinklogical's VX Router uses two methods for secure routing. One is known as **Restricted Switching** and the other is known as **Partitioning**. These methods can be deployed singularly or jointly, depending on security requirements.

Restricted Switching

Restricted Switching provides multiple levels of security classification domains on the same VX Router. Each destination must ensure that no unauthorized content is displayed or accessed, therefore, each input and output needs to be prioritized. Priorities can range from 1 to the total number of ports in the VX Router. An output can connect to an input with a priority greater than, or equal to, its priority. Thus, a priority level of 1 on an output can connect to any input (priority 1, 2, 3...).

The user must provide a table defining the priorities for each input and output of the switch matrix. This table is in the form of a comma separated value (csv) file. This file contains the values in three columns: **Port Direction** (i=input, o=output), **Port Number** and **Port Priority**. For example:

I/O	Number	Priority
"i",	1,	1
"i",	2,	2
"i",	3,	3
"i",	4,	1
"i",	5,	3
"o",	1,	1
"o",	2,	3
"o",	3,	2
"o",	4,	4
"o",	5,	1

- Output 1 can connect to ports 1-5.
- Output 2 can connect to ports 3 and 5.
- Output 3 can connect to ports 2, 3, and 5.
- Output 4 cannot connect to any ports.
- Output 5 can connect to ports 1-5.

Note that Port Direction (i or o) is in quotes and that the table must use only the following ASCII printable characters:

Double quotes (or speech marks),	character code = 34	(")
Lower case i	character code = 105	(i)
Lower case o	character code = 111	(o)
Comma	character code = 44	(,)
Carriage Return	character code = 13	(CR)
Line Feed	character code = 10	(LF)

The VX Router will interpret the Restricted Switching Table (csv file) during the boot-up. Any errors that occur during the Restricted Switching Table interpretation process will be logged in the messages file at the following location: **var/log/messages**

It is recommended that the **Messages File** be reviewed and any errors in the Restricted Switching Table be corrected before implementing multiple levels of security classification domains on the same VX Router. It is also recommended that **Restricted Switching** be fully tested before implementing multiple levels of security classification domains on the same VX Router.

The Restricted Switching Table files for the VX Routers are stored on the Controller Card at the following location:

var/local/router/restrict/upstream.csv
var/local/router/restrict/downstream.csv

Restricted switching is disabled when Restricted Switching Table files are removed. By default, when there are no Restricted Switching Table files, all input and output ports will have a priority of 1. All VX Routers are shipped without Restricted Switching Table files stored on the Controller card and therefore do not restrict any connection.

Restricted Switching with VX Routers

Restricted Switching Priority Scheme

The following example shows a priority scheme for four levels of security managed by one VX Router:

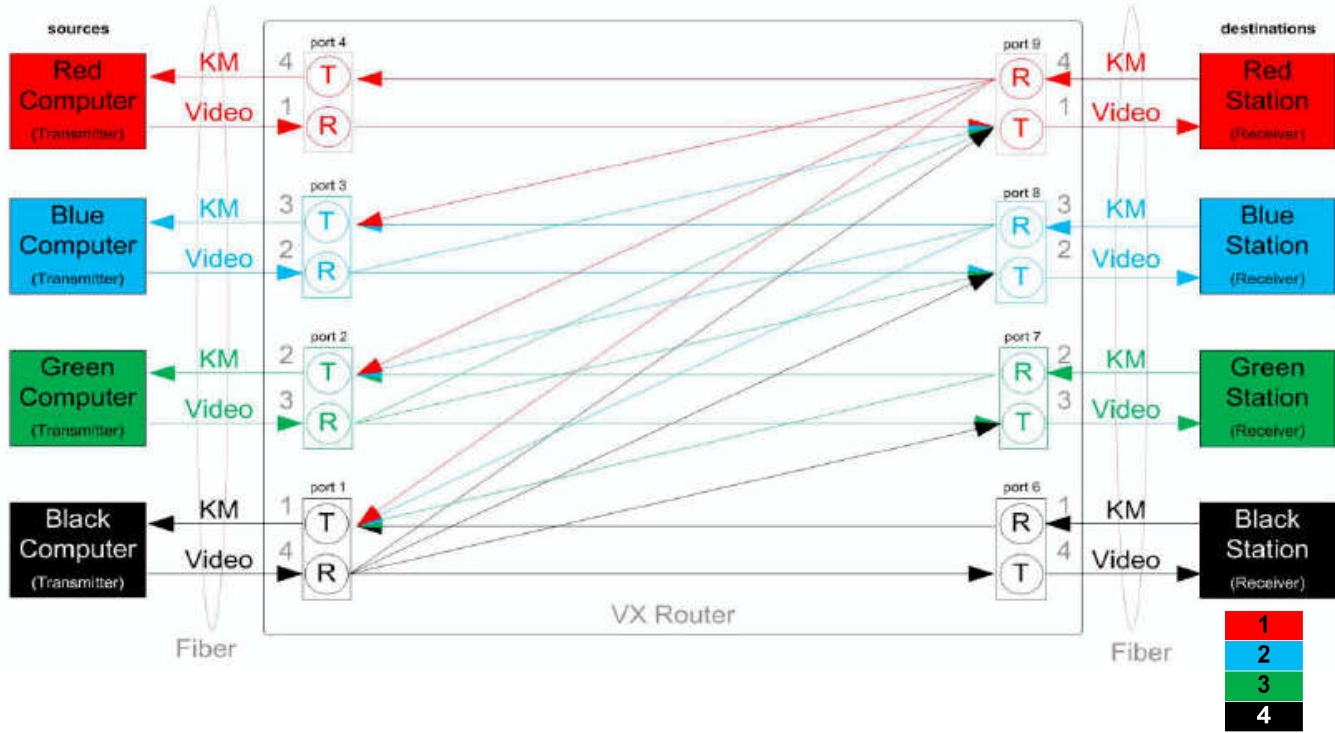

For Video:

- Destination workstations in the **RED** network can see what is transmitted by source computers in the **BLACK, GREEN, BLUE & RED** networks.
- Destination workstations in the **BLUE** network can see what is transmitted by source computers in the **BLACK, GREEN & BLUE** networks.
- Destination workstations in the **GREEN** network can see what is transmitted by source computers in the **BLACK & GREEN** networks.
- Destination workstations in the **BLACK** network can see what is transmitted by source computers in the **BLACK** network only.

For Keyboard & Mouse:

- Destination workstations in the **RED** network can control source computers in the **BLACK, GREEN, BLUE & RED** networks.
- Destination workstations in the **BLUE** network can control source computers in the **BLACK, GREEN & BLUE** networks.
- Destination workstations in the **GREEN** network can control source computers in the **BLACK & GREEN** networks.
- Destination workstations in the **BLACK** network can control source computers in the **BLACK** network only.

• Restricted switching is configured via firmware loaded into the VX Router. The configuration file for this scenario would look like this (where the first value is "i" for input or "o" for output, the second value is the port number and the third value is the priority level).

Important Notes:

- In this scenario, ports 1-4 in card 1 and ports 6-9 in card 2 are used. However, any ports on any cards can be used. (Each card has five ports numbered 1-5, bottom to top.)
- The number of priority levels that can be managed by one VX Router is the same as the number of ports in the VX Router: The VX40 and VX80 can support 80 priority levels. The VX160 can support 160 priority levels and a VX320 or VX320Video can support 320 priority levels.

```

"i",1,4
"i",2,3
"i",3,2
"i",4,1
"o",6,1
"i",7,2
"i",8,3
"i",9,4
"o",1,1
"o",2,2
"o",3,3
"o",4,4
"o",6,4
"o",7,3
"o",8,2
"o",9,1
    
```



Note: When using a Back-up Controller configuration, both controllers must have the same Restricted Switching Table file(s).

Partitioning

Partitions allow VX Router sources and destinations to be segregated. Therefore, destination work stations will only receive signals that are transmitted from source computers in the same partition. In addition, it is impossible for a source computer to be inadvertently routed outside of its designated partition as the signals will not be transmitted.

Example: VX80 Router with four distinct partitions:

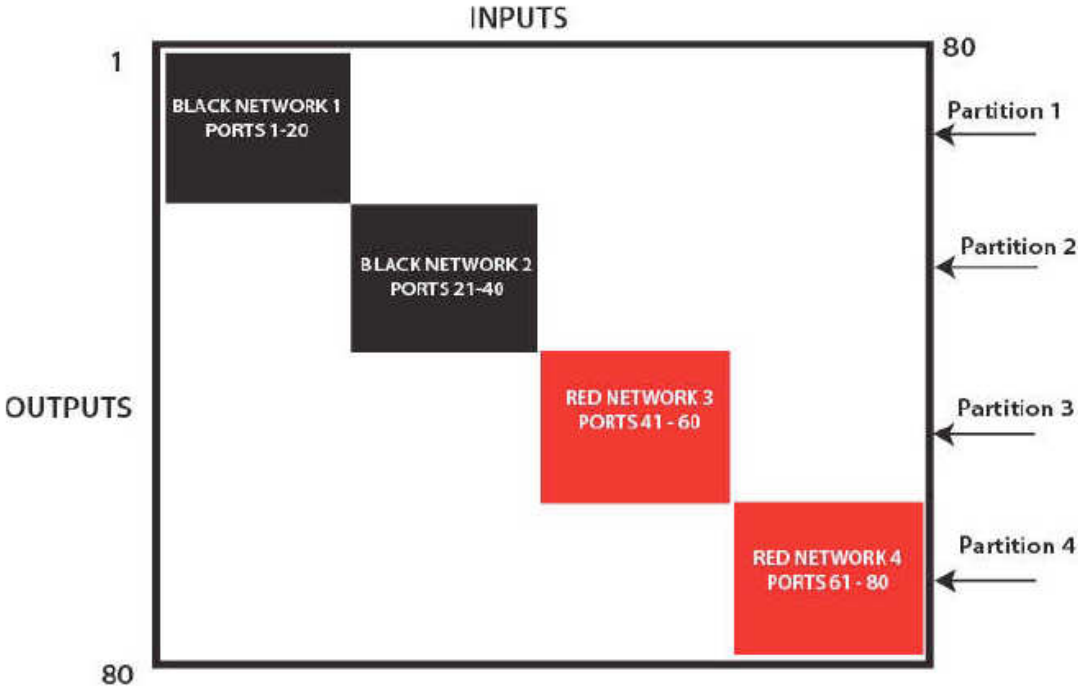

Four partitions set up for secure routing and extension applications. Signals are only capable of transmitting and receiving within a single partition and not across partitions

The maximum number of partitions is the number of ports that make up the VX Router (80, 160, 320, 640). A VX40 or VX80 Router can be configured with up to 80 partitions, a VX160 up to 160, and so forth. There are also overlapping partition configurations.

The following example shows a VX80 Router with an overlapping partition:

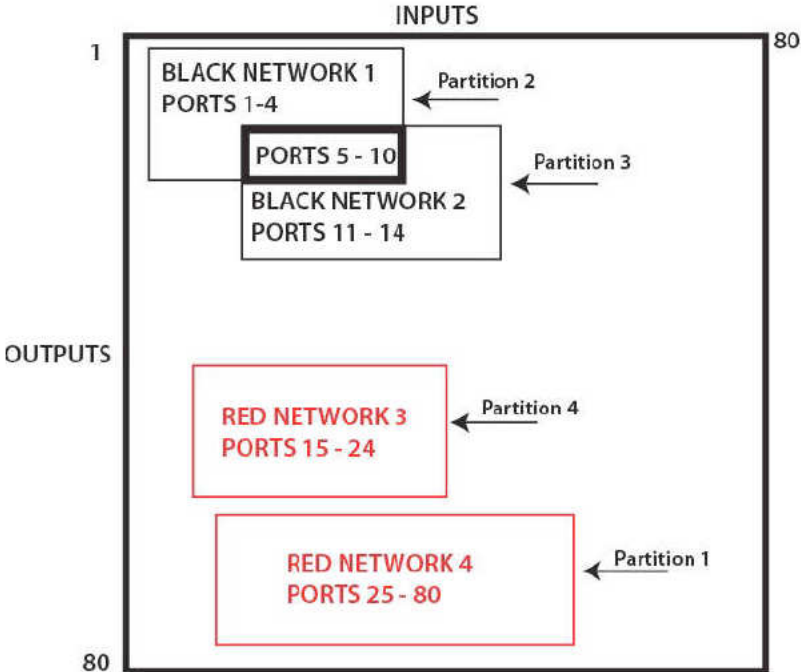

A VX80 with four partitions: Ports 5-10 are accessible to both partitions 2 and 3.

The user must provide a table defining the partitions. This table is in the form of a comma separated value (CSV) file located in `/var/local/router/partition` on the VX Router. This file contains the port number and the partitions to which it belongs. The configuration file for the above scenario looks like this:

“Port,”	“Partition”	“Port,”	“Partition”
1,	2	13,	3
2,	2	14,	3
3,	2	15,	4
4,	2	16,	4
5,	2,3	17,	4
6,	2,3	18,	4
7,	2,3	19,	4
8,	2,3	20,	4
9,	2,2	21,	4
10,	2,3	22,	4
11,	3	23,	4
12,	3	24,	4

All ports not listed will default to partition 1. Ports can be manually added to partition 1.



Note: When using a Back-up Controller Card configuration, both controllers must have the same Partition table.

Administration Access

There are only two methods by which the administrator can access the VX Router Controller Configurations:

- 1. Using the serial console directly connected to the VX Router:** It should be noted that, while no administrator password is required to use the serial console (by default), physical access to the router is required. Therefore, the router should be stored in a physically secure location to avoid unauthorized access. The serial console can be configured to require an administrator password that will assume the same security that is listed below, under “Password Security.”
- 2. Using SSH access:** The router allows SSH connections to the router for management purposes. SSH sessions are authenticated using an encrypted password file.
- 3. Password Security:** For security purposes, the router defaults to using the Message-Digest Algorithm (MD5) and shadow passwords. **It is highly recommended that you do not alter these settings.** If you select the older Data Encryption Standard (DES) format, passwords will be limited to eight alphanumeric characters (disallowing punctuation and other special characters) with a modest 56-bit level of encryption. **The single most important thing you can do to protect the router is create a strong password.**
- 4. Creating Strong Passwords:** The password can contain up to 127 characters and cannot contain a space.
 MAKE THE PASSWORD AT LEAST EIGHT CHARACTERS LONG. The longer the password, the more effective it will be. If you are using an MD5 password, it should be approximately 15 characters long. With DES passwords, use the maximum eight character length.

 MIX UPPER AND LOWER CASE LETTERS. Passwords are case sensitive, so mixing will multiply the number of possible combinations.

 MIX LETTERS AND NUMBERS. Intersperse numbers within the password to enhance its strength.

INCLUDE NON-ALPHANUMERIC CHARACTERS. Special characters (& \$ % >) and punctuation marks (? " !) increase the strength of a password.

Secure Application Examples

The Diagrams on pages 62-66 show each of the VX Matrix Routers in a secure application. **The highly secure components are described as the Red Network and the other, lower security components are described as the Black Network.** The Red Network, containing the computers (sources), is shown in a physically secure environment along with the VX Router, the computer server used to manage the Router, and the Network Hub. The Network Hub is a dedicated network used only to connect the VX Router to the computer server. This dedicated network does not connect to any other components and does not extend beyond the physically secure environment. The dedicated network connection may be replaced by a direct serial connection (RS-232) between the VX Router and the computer server.



Note: The VX Router and the computer server used to manage the Router must be protected according to the highest security classification of any component in the entire network application.



Note: The optical connections and DESTINATION receiver designated as Red Network must be physically secure.

The VX Router can be configured to prevent accidental connection from the Red Network to the Black Network using the Restricted Switching feature. For example, a VX Matrix Router could be configured with the following csv file:

```
I,1,2  
I,2,2  
O,2,2  
I,42,2  
O,41,2  
O,42,2  
I,5,1  
O,5,1  
I,45,1  
O,45,1
```

The following connection rules will apply:

SOURCE 2 can be connected only to DESTINATION 2.

SOURCE 1 can be connected to both DESTINATION 1 and DESTINATION 2.

The configuration of the VX Router should be reviewed regularly to ensure that it continues to meet organizational security policies concerning:

- Changes in the VX Router configuration
- Changes in the organizational security policy
- Changes in the threats presented from non-trusted network interfaces
- Changes in the administration and operation staff or the physical environment of the VX Router



thinklogical™
router
VX40
KVM Matrix Switch
 Powered by
MRTS Technology

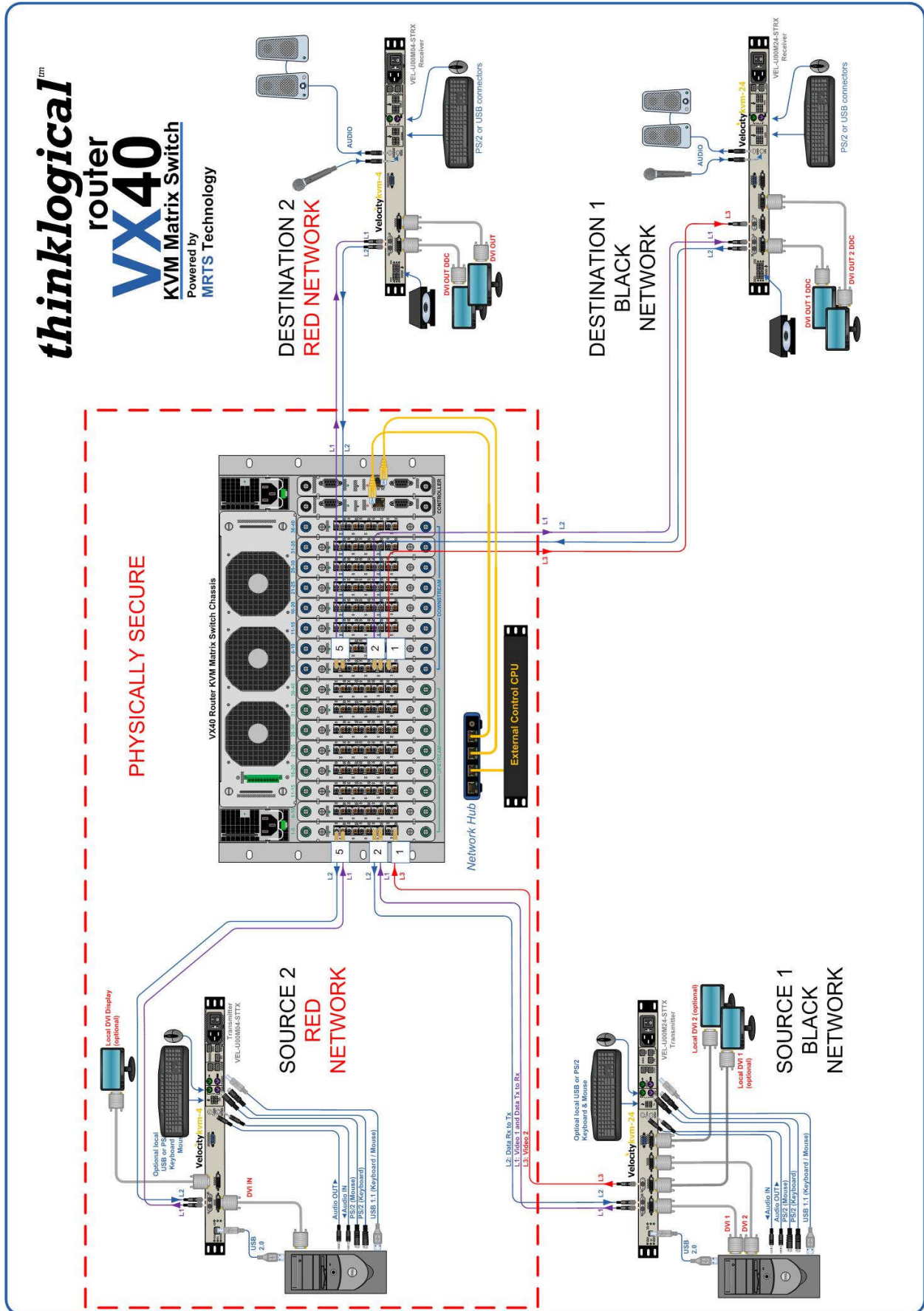

VX40 Secure Application

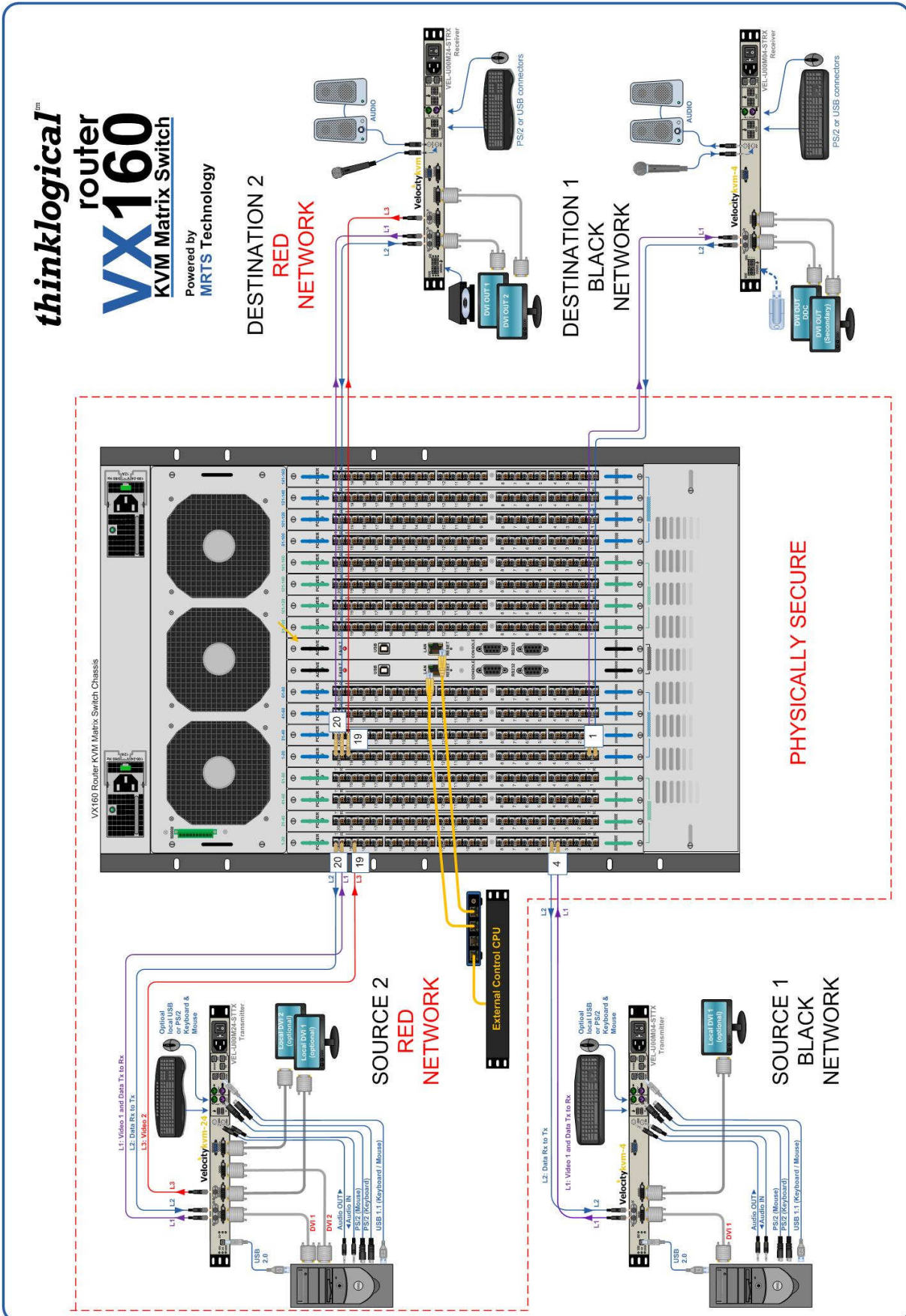

VX160 Secure Application

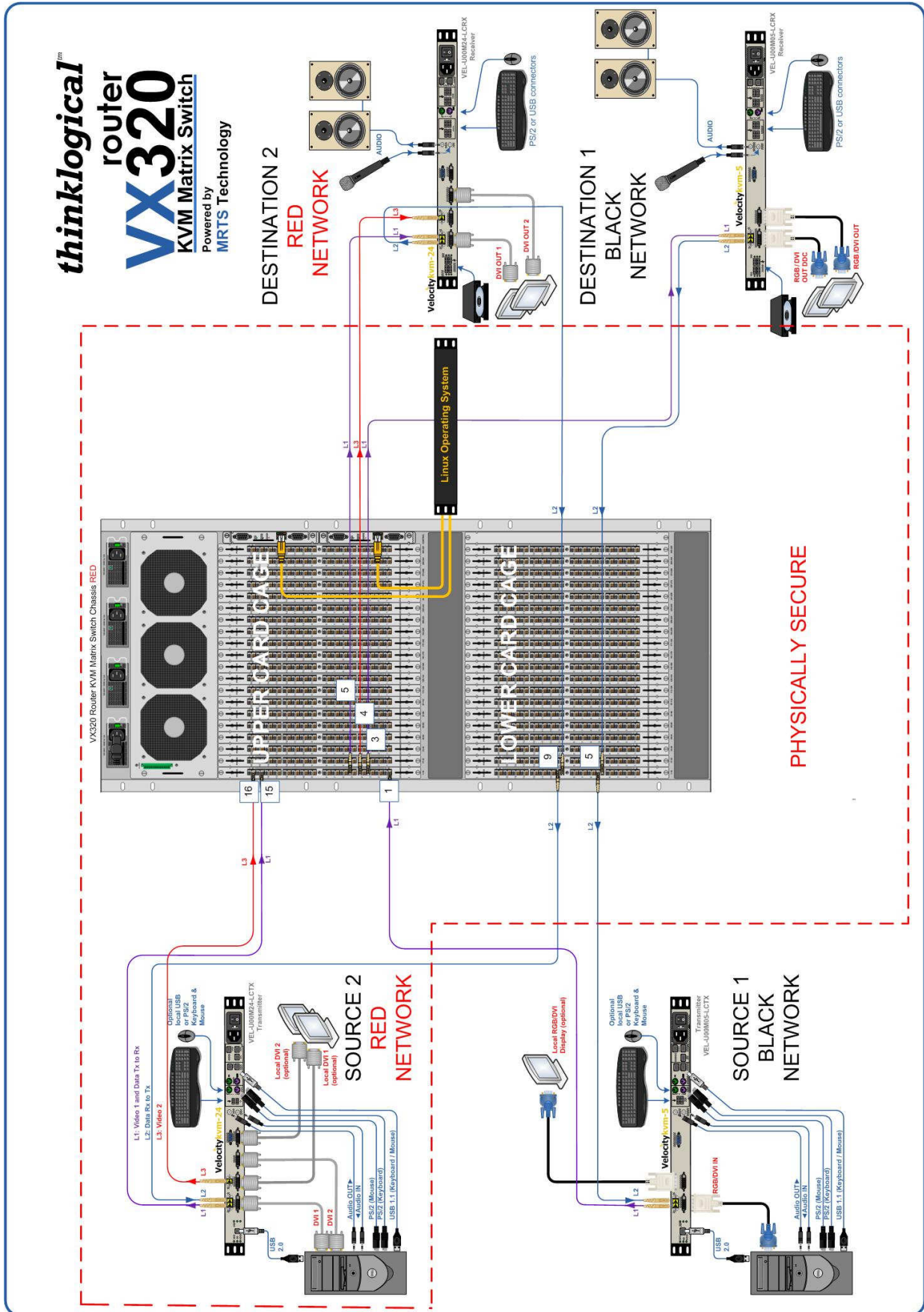

VX320 Secure Application

thinklogical
VXVIDEO
320router

Powered by
MRTS Technology

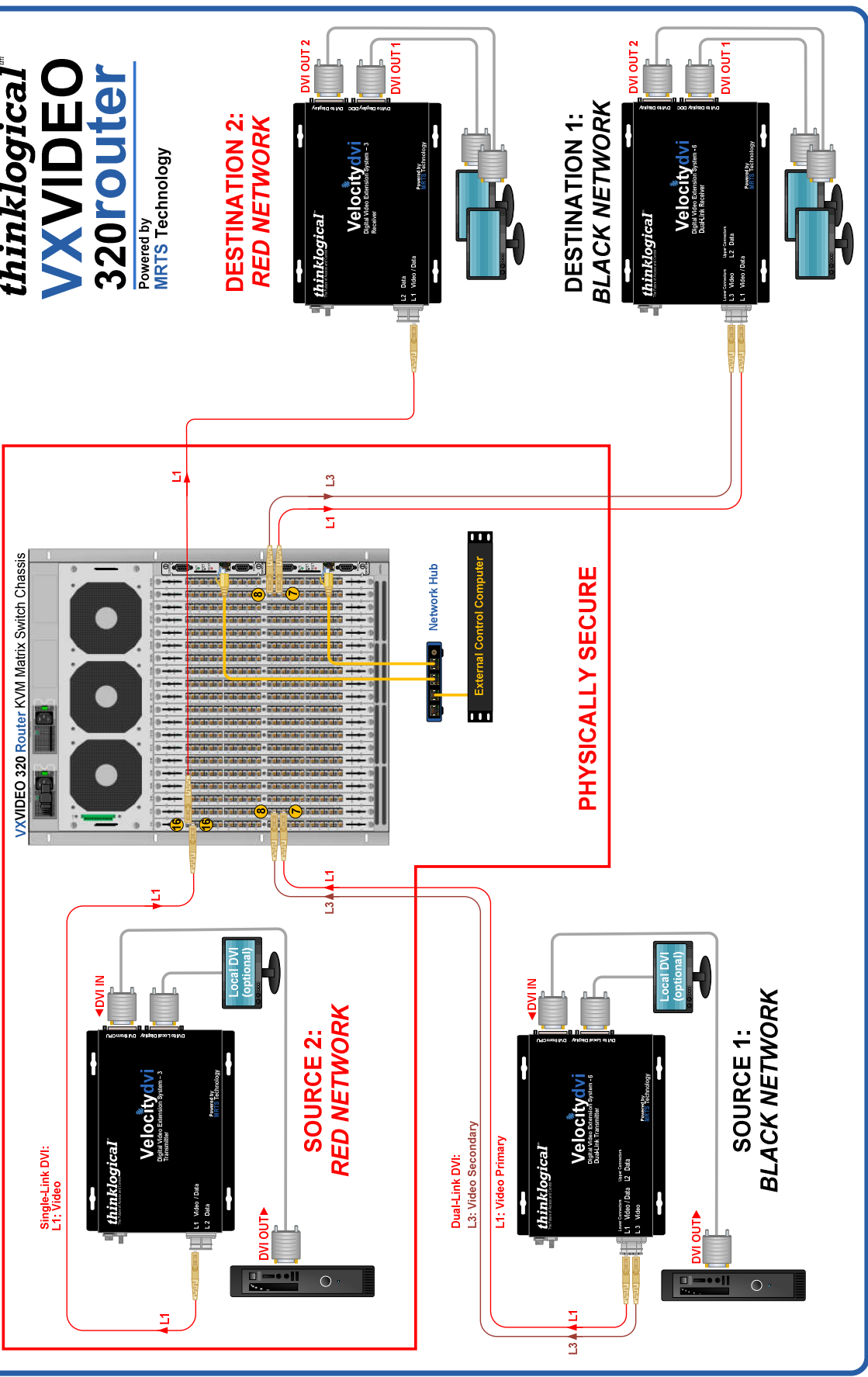

VX320 Video Secure Application

APPENDIX E: Touch Panel Configuration

Thinklogical supplies 5.7" and 9" touch panels. These are small, Linux computers that run a borderless version of the Chromium browser. On power up, they start the browser with the URL of the X4 server and load the page that's been specified for them with X4's GROUPS page.

Configuration:

By default, the touch panels are delivered with DHCP networking. In most cases, they will need to be made **static**.

There are two ways to modify the configuration on a touch panel:

1. Use a USB keyboard connected directly to the touch panel and make any necessary changes **directly** on that panel.
2. Connect the touch panels to a network and log into them **remotely**. Both methods are described below.

In both cases, you will first need to know the IP address of the web server and decide an appropriate IP address of the touch panel(s) before configuring them.

Direct Configuration:

1. Attach the USB keyboard to a USB port on the Touch Panel
2. Press **Ctrl - Alt - F1** on the Touch Panel to go into text mode
3. When the login prompt appears, login as **root** with password **emac_inc**

Remote Configuration: Each touch panel is shipped with DHCP enabled by default.

1. Attach one or more touch panels to a network with a DHCP server
2. Use "ssh" to access each touch panel in turn as in **ssh root@192.168.7.112**
Password: **emac_inc**

```
mba:~ alex$ ssh root@192.168.7.112
root@192.168.7.112's password:
Last login: Thu Oct 11 13:14:31 2012 from 192.168.7.100
vortex86:~# cd /etc/network
vortex86:/etc/network# vi interfaces
```

To set up the network:

1. Type `cd /etc/network`
2. Using `vi`, edit "interfaces"
3. In the section for `eth0`:
 - a. Modify the `dhcp` line to say "static"
 - b. Insert a line "address 192.168.13.161" (with the chosen IP address for this Touch Panel)
 - c. Add "netmask 255.255.255.0"
 - d. Save and exit

The new interfaces file should look something like this after modification:

```
# /etc/network/interfaces -- configuration file for ifup(8), ifdown(8)

# The loopback interface
auto lo
iface lo inet loopback

allow-hotplug eth0
iface eth0 inet static
    address 192.168.13.112
    netmask 255.255.255.0
    network 192.168.13.0
    broadcast 192.168.13.255
    gateway 192.168.13.1
```

To set the browser to find the server:

Edit **/home/user/homepage** to match your installation:

```
vortex86:~# cd /home/user
vortex86:/home/user# vi homepage
```

This is a one line file. Change the IP address to match that of the web server (also called the “Control Computer”) for your installation and remove “touch” from the line (if it is present).

```
http://192.168.13.9/touch
~
~
~
~
~
I homepage [Modified] 1/1 100%
```

It should look something like this when finished:

```
vortex86:/home/user# cat homepage
http://192.168.13.9/
vortex86:/home/user#
```

Save and exit

The files have now been configured, but the Touch Panel will not use them until the next two steps are performed:

```
vortex86:/home/user# sync
vortex86:/home/user# reboot
```

The touchpanel will now automatically load the page selected in the GROUPS page.

Groups/Users Administration

Import Export **SAVE** Cancel

Click inside any cell to change the contents of that cell, *right-click* inside any cell to see additional row options, *right-click* inside any *column header* to add or delete columns (if appropriate), and press the **SAVE** or **Cancel** buttons (above) when changes are complete.

Logins Required:	Default Group:	Restore on Restart:
yes	admin	no

Group definitions

Group Name:	Startpage:	Page:	Page:	Page:	Page:	Page:	Page:	Page:
admin	connect	admin	macros	studio	combi	groups		
user	studio	combi	macros	touchscreen				
touch	combi-m	macros						

User definitions

Username:	Group:	Local Password:
admin	admin	admin
user	user	user

Groups assigned by IP address (touchpanels)

IP Address:	Group:	Comment:
192.168.13.112	touch	

In the configuration shown above, the touchpanel with the IP address of 192.168.13.112 will load the startpage combi-m (or COMBI-M).

COMBI-M is a COMBI page with an additional MACRO button at the bottom right. This button lets the user also access the Macros page and then return to the COMBI page.

In ADMIN Stations we have made some source stations Takeable for the group “touch”:

Source Name:	Router Name:	L1:	L2:	L3:	Category:	Category:	Takeable:	Color:
Src 1	A	UR-001	UT-001		ALL		touch	fuchsia
Src 2	A	UR-002	UT-002		ALL		touch	lime
Src 3	A	UR-003	UT-003		ALL		touch	blue
Src 4	A	UR-004	UT-004		ALL		touch	red
Src 5	A	UR-005	UT-005		ALL		touch	purple
Src 6	A	UR-006	UT-006		ALL		touch	orange
Src 7	A	UR-007	UT-007		ALL		touch	yellow
Src 8	A	UR-008	UT-008		ALL		touch	green
Src 9	A	UR-009	UT-009		ALL		touch	navy
Src 10	A	UR-010	UT-010		ALL		touch	aqua
Src 11	A	UR-011	UT-011		ALL		touch	fuchsia

As well as some destination stations:

Destination Name:	Router Name:	L1:	L2:	L3:	Category:	Takeable:	Category:
Dst 1	A	UT-041	UR-041		ALL	touch	
Dst 2	A	UT-042	UR-042		ALL	touch	
Dst 3	A	UT-043	UR-043		ALL	touch	
Dst 4	A	UT-044	UR-044		ALL		
Dst 5	A	UT-045	UR-045		ALL		
Dst 6	A	UT-046	UR-046		ALL		

In ADMIN Macros, we have made “mac 1” available to “touch”

Administration

Select from the tabbed choices above

SAVE Cancel

Click inside any cell to change the contents of that cell, right-click inside any cell to see additional row options, right-click inside any column header to add or delete columns (if appropriate), and press the SAVE or Cancel buttons (above) when changes are complete.

mac 1 New Name? (or leave unchanged) mac 1

Delete This Macro

Groups that can see this macro

Group:	Group:	Group:	Group:	Group:	Group:	Group:	Group:
user	touch						

Action:	Destination:	Source:
SHARE	Dst 3	Src 1
SHARE	Dst 6	Src 1
SHARE	Dst 1	Src 2
VIEW	Dst 2	Src 1
SHARE	Dst 8	Src 9

The touchscreen at 192.168.13.112 will now start up in this page:

The screenshot shows a touchscreen interface with a dark background. At the top, there's a teal header labeled 'SOURCES'. Below it, an 'ALL' button is visible. A grid of source buttons (Src 1-8) is shown, with Src 1 highlighted in orange. Below the sources, there are destination buttons (Dst 6*, Dst 3, Dst 31*, Dst 11*, Dst 8*). A blue header labeled 'DESTINATIONS' is below that, with an 'ALL' button and three destination buttons (Dst 1, Dst 2, Dst 3). At the bottom, there's a navigation bar with the thinklogical logo and buttons for TAKE, SHARE, VIEW, BREAK, LOCK, UNLOCK, and MACROS.

and when the MACROS button at the bottom right is pressed, it will show this page:

Macros

Pressing a button (below) will execute that macro

Macro from History

mac 1

The COMBI-M link at the top will return to the COMBI page.

APPENDIX F: MIB FILE

The MIB (**M**anagement **I**nformation **B**ase) file contains information on the operational status of the VX Router hardware. The file is located on our FTP site and on the install disk included with your VX Router. It is also included on the VX Router SD Card in the directory

/user/share.snmp/mibs

LSI-ROOT.txt

LSI-ROUTER-API-INTERFACE.txt

LSI-SFP.txt

LSI-VXROUTER.txt